

D-BOX G5



G5 HAPTIC SYSTEM

USER GUIDE

TABLE OF CONTENTS

IMPORTANT SAFETY INSTRUCTIONS..... 4

G5 HAPTIC SYSTEM SPECIFICATIONS AND COMPONENTS..... 6

1. INTRODUCTION..... 9

2. INSTALLATION GUIDELINES 10

 2.1 Minimum Spacing Between Actuators 10

 2.2 Haptic Actuator Alignment 10

 2.3 Haptic Actuator Levelling 11

 2.4 Level Surface..... 11

 2.5 Weight Distribution 11

3. VOLTAGE SELECTION..... 12

4. HAPTIC ACTUATOR ENDING INSTALLATION..... 12

 4.1 Non-Captive Ending Installation (Optional) 12

 4.2 Captive Ending Installation..... 13

5. BRACKET INSTALLATION 17

 5.1 U-Bracket Installation 17

 5.2 L-Bracket Installation..... 17

6. CONNECT YOUR HAPTIC SYSTEM 18

 6.1 1-Actuator Configuration 18

 6.2 2-Haptic Actuator Configuration..... 19

 6.3 3-Haptic Actuator Configuration..... 19

 6.4 4-Haptic Actuator Configuration..... 20

 6.5 Haptic Expander 20

7. CREATE YOUR D-BOX CONNECT ACCOUNT 25

8. SOFTWARE INSTALLATION..... 25

 8.1 Minimum System Requirements (PC)..... 25

9. D-BOX SYSTEM CONFIGURATOR..... 26

10. D-BOX HAPTISYNC CENTER 28

 10.1 Haptic Output Tab 29

 10.2 D-BOX Adaptive Gaming Configurator 31

 10.3 D-BOX System Monitor Recorder 32

 10.4 D-BOX Stimuli Presenter 33

11. HAPTIC SYSTEM OPERATION..... 33

12. TROUBLESHOOTING 34

 12.1 Initial Troubleshooting Steps 34

 12.2 Reinitiate Your Haptic System..... 34

 12.3 Update Software and Firmware 36

 12.4 Troubleshooting with Haptic Bridge LED Statuses 37

 12.5 Troubleshooting Hardware Issues (HaptiSync Center) 38

 12.6 Faults and Corrective Actions 40

12.7 Troubleshooting Software Issues (D-BOX HaptiSync Center)43
APPENDIX A - MIXING G5 AND G3 HAPTIC SYSTEMS (ACM G3 FLEX ONLY)46

WWW.SIMULTIMATE.EU

IMPORTANT SAFETY INSTRUCTIONS

- Read, keep, and follow these instructions.
- Heed all warnings.



This D-BOX haptic system may be harmful to women who are pregnant, persons with heart conditions, the elderly, or those with other pre-existing medical conditions. All such persons should consult their physicians before using this D-BOX haptic system.



Use of this D-BOX haptic system is not recommended for children under the age of ten years old without adult supervision. Owners and/or users of this D-BOX haptic system should consult and comply with the user guide enclosed.



Use of this D-BOX haptic system is a risk to hands and feet. Do not put hands or feet underneath the seat or near the haptic system. This may lead to serious injury.



Unplug this device during electrical storms or when unused for long periods of time.



Use of hot liquids in the vicinity of this D-BOX haptic system should always be avoided to prevent spillage which could cause serious injuries to the user.



Do not install near any heat sources such as radiators, heat registers, stoves or any other appliances (including amplifiers).



Do not use this device near water.



Refer all servicing to qualified personnel. Servicing is required when the device has been damaged in any way. For example: if liquid has been spilled or objects have fallen onto it, if it has been exposed to rain or moisture, if it does not operate normally or it has been dropped.

- Only clean the device with a dry cloth.
- Do not block any ventilation openings.



- Install in accordance with the manufacturer's instructions.
- Protect all the cables (USB, network, power, etc.) from being walked on or pinched, particularly at the ends.
- Use only attachments/accessories specified by the manufacturer.

Owners and/or users of this D-BOX haptic system are responsible for the dissemination of this information to all such persons named herein. Each owner and/or user of this D-BOX haptic system agrees to evaluate and bear all risks associated with the use of this D-BOX haptic system for themselves and for any subsequent users of this D-BOX haptic system and any subsequent users of this D-BOX haptic system shall be deemed to be using this D-BOX haptic system under the direct supervision of such owner/user and such owner/user will be deemed to have communicated this advisory to all persons described herein.

D-BOX Technologies Inc. is in no way responsible for any damages of any kind arising from the use of this D-BOX haptic system and the owners and/or users of this D-BOX haptic system hereby agree not to hold D-BOX Technologies Inc. responsible for any and all damages of any kind arising from the use of this D-BOX haptic system, including but not limited to direct or indirect, punitive, incidental, special or consequential damages arising out of or in any way connected with the use of this D-BOX haptic system.

Thank you for purchasing a D-BOX haptic system, an extremely immersive experience for the simulation and game markets. We strongly advise that you read these guidelines before assembling and using your haptic system.

Please make sure to provide the **serial numbers** (Haptic Bridge and Haptic Actuators) of your haptic system when contacting your reseller support team (or the D-BOX Technical Support team if you are an integrator and your system was bought directly from D-BOX).

The serial numbers (in yellow) are located on the haptic components and available (in its shortened form) under Diagnostics in the Haptic Output tab of D-BOX HaptiSync Center.



D-BOX 231-00-XXXXX
S/N: 



822-N002
D-BOX 242-06-XXXXX
S/N: 

If you have questions:

- Contact your official D-BOX reseller
- Reach out to D-BOX [Technical Support](#) if you purchased directly from D-BOX
- Visit the Help Center section of our [website](#) to access our Knowledge Base or chat with D-Buddy, our chatbot

If remote assistance is required, ensure that you have [TeamViewer](#) installed on your PC.

D-BOX Technical Support

2172 rue de la Province, Longueuil, Québec, Canada, J4G 1R7

BY EMAIL: support@d-box.com

BY PHONE: 1-888-442-3269 ext. 931 (toll-free CAN/US)
1-450-442-3003 ext. 931 (other regions)



G5 HAPTIC SYSTEM SPECIFICATIONS AND COMPONENTS

PERFORMANCE UNDER MAXIMUM LOAD	
MAXIMUM LIFTING CAPACITY PER ACTUATOR	250 lb / 113 kg
HORIZONTAL LOAD	Translation on limited friction surfaces can be done on weights up to 3 times vertical lifting capacity.
MAXIMUM STROKE	1.5 inch / 38.1 mm
MAXIMUM VELOCITY	100 mm/s
MAXIMUM ACCELERATION	+/- 1g-force
FREQUENCY RANGE	0-100 Hz
OPERATING TEMPERATURE RANGE	0-40°C
OPERATING HYGROMETRY	10 to 85% (free from condensing)

POWER REQUIREMENTS		AVERAGE POWER To be used for electric consumption	AVERAGE POWER To be used for converter specification	PEAK CURRENT To be used for breaker specification
120 V 50/60 HZ	1 ACTUATOR	150 W	240 VA	2 A
	2 ACTUATORS	270 W	470 VA	4 A
	3 ACTUATORS	420 W	710 VA	6 A
	4 ACTUATORS	540 W	940 VA	8 A
230 V 50/60 HZ	1 ACTUATOR	150 W	260 VA	1.1 A
	2 ACTUATORS	270 W	480 VA	2.1 A
	3 ACTUATORS	420 W	740 VA	3.2 A
	4 ACTUATORS	540 W	960 VA	4.2 A

OPTIONAL G5 COMPONENTS
CAPTIVE ENDING, AC218, 1 AXIS 0330, w/ SPACER RETAINER
CAPTIVE ENDING, AC218, 2 AXIS 0563, w/ SPACER RETAINER
CAPTIVE ENDING, AC218, 1 AXIS, w/ ROTULE ANCHOR
L-BRACKETS
U-BRACKETS

BRACKET OPTIONS



ENDING OPTIONS



G5 HAPTIC SYSTEM KITS

Kit of 4 Haptic Actuators* (822-K004)	
Qty.	Description
4	HAPTIC ACTUATOR G5 - HA201 (M1-250 AC218 63") (822-N001)
1	HAPTIC BRIDGE G5 - HB140 (822-N002)
1	CABLE, USB A-MALE TO USB B-MALE, 1.8 M (000-090-0126-Z00)
1	CABLE, EXTENSION, USB-A 3.0 MALE TO USB-A 3.0 FEMALE, SHIELD, 10 ft. (000-090-0137-Z00)
2	CABLE, AC, C14 STRAIGHT TO DUAL C13 STRAIGHT, 10A/250V, 3x16 AWG, 0.3M (Y-Splitter) (000-090-0125-Z00)
7	PLUG LOCK INSERT FOR IEC C13 CONNECTOR (000-090-0103-Z00)
4	(NON-CAPTIVE) CUP ENDING v2, ALUMINIUM (810-0020)
16	SCREW, SERRATED-FLANGE BOLT, HEX, M6 x 1 x 16 mm, BLACK ZINC (000-100-0616-Z00)
3	POWER CORD

Kit of 2 Haptic Actuators* (822-K002)	
Qty.	Description
2	HAPTIC ACTUATOR G5 - HA201 (M1-250 AC218 63") (822-N001)
1	HAPTIC BRIDGE G5 - HB140 (822-N002)
1	CABLE, USB A-MALE TO USB B-MALE, 1.8 M (000-090-0126-Z00)
1	CABLE, EXTENSION, USB-A 3.0 MALE TO USB-A 3.0 FEMALE, SHIELD, 10 ft. (000-090-0137-Z00)
1	CABLE, AC, C14 STRAIGHT TO DUAL C13 STRAIGHT, 10A/250V, 3x16 AWG, 0.3M (Y-Splitter) (000-090-0125-Z00)
4	PLUG LOCK INSERT FOR IEC C13 CONNECTOR (000-090-0103-Z00)
3	(NON-CAPTIVE) CUP ENDING v2, ALUMINIUM (810-0020)
1	PIVOT, DELRIN, AC7, (Rev -) (132-0021)
1	SCREW, SOCK.HEAD, CAP, 1/4-20 X 2 (100-0356)
4	SCREW, SERRATED-FLANGE BOLT, HEX, M6 x 1 x 16 mm, BLACK ZINC (000-100-0616-Z00)
2	POWER CORD

*Kits can be purchased with various amounts of Haptic Actuators. Consult your D-BOX reseller for details.

G5 HAPTIC BRIDGE

HB140 (USB)

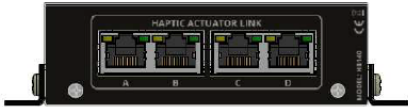

HB240 (USB and KineChain)

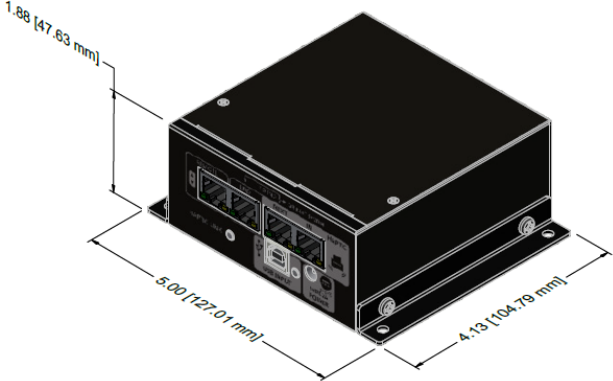
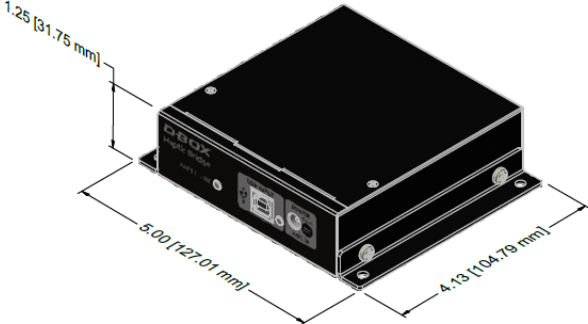
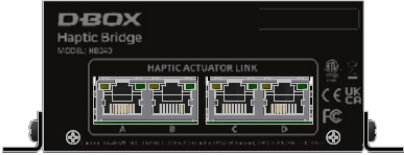

G5 HAPTIC ACTUATOR

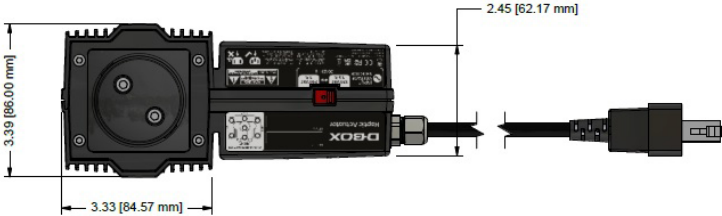
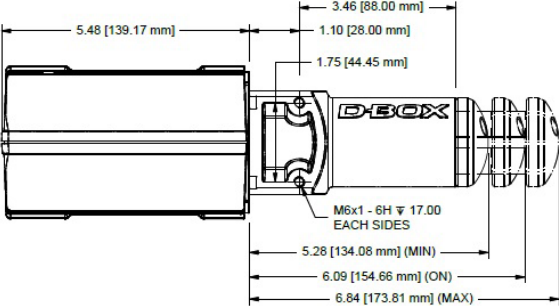
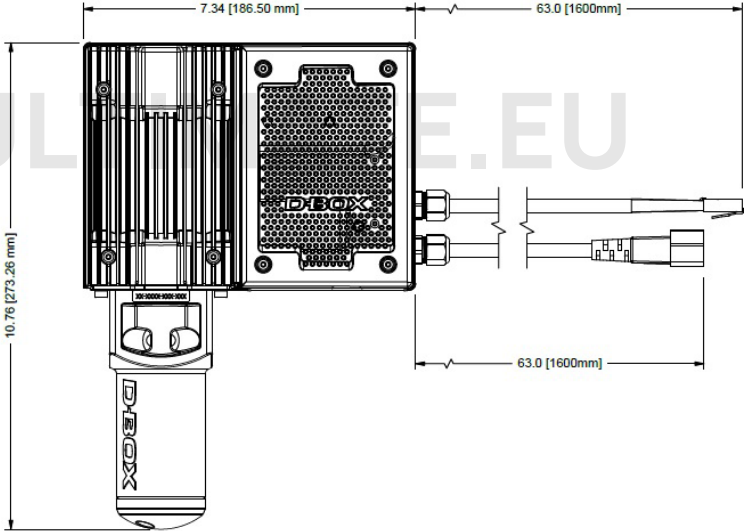
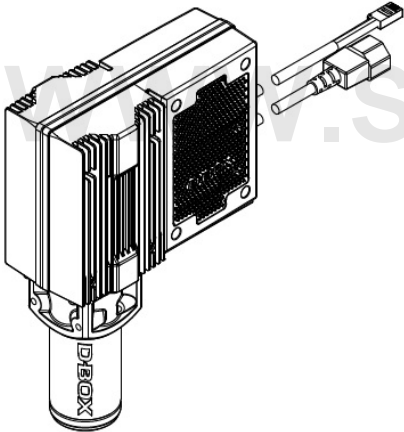

1. INTRODUCTION

The G5 haptic system delivers a high level of performance, realism, and reliability, all within a compact and streamlined form factor that emphasizes simplicity in infrastructure and connectivity. The G5 haptic system is a flexible solution, making the operation and installation of our systems easier than ever before, without the need for multiple large ACM boxes. The Haptic Bridge gathers data of up to four actuators in a single control box that is significantly smaller than other designs. Also, each individual actuator has its own voltage selector, letting users go between 120 and 230V with the flick of a switch.

The following components are part of a D-BOX G5 haptic system.



- **Haptic System:** A complete architecture of hardware and software providing motion, textures, and vibrations.
- **Haptic Actuator:** An assembly of motor and mechanics providing motion, textures, and vibrations.
- **Haptic Bridge:** A communication module controlling 1 to 4 haptic actuators.
- **Haptic Source:** Devices or applications generating haptic data for the D-BOX haptic system.

2. INSTALLATION GUIDELINES

When integrating your D-BOX G5 haptic system, comply with the following guidelines. This will help you keep your product healthy and maximize its life span. If you must deviate from the guidelines, please [contact us](#) to make sure you are still using the system as prescribed.

2.1 Minimum Spacing Between Actuators

Respect the minimum spacing between actuators for adequate movement of the platform. Measure the distance using a **square surface enclosing all actuators** (see example below). Respecting the spacing guidelines ensures proper interaction of the haptic system with the actuator endings, and proper lateral force transfer.

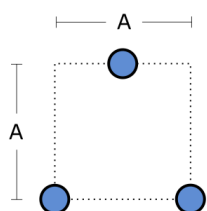

TRAVEL	MINIMUM SPACING BETWEEN ACTUATORS (A)
1.5 in	14 in [356 mm]

2.2 Haptic Actuator Alignment

When using two haptic actuators + pivot, or three haptic actuators, install them in an isosceles triangle pattern.

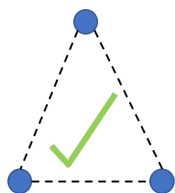

Adequate actuator integration

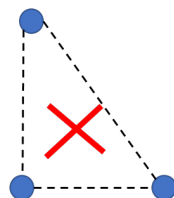

Inadequate actuator integration

When using four haptic actuators, install them in a square or rectangular pattern.

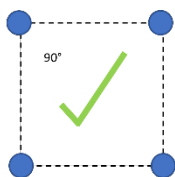

Adequate actuator integration (square/rectangular)

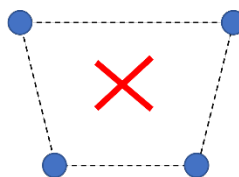

Inadequate actuator integration

2.3 Haptic Actuator Levelling

During installation, the actuators must always remain straight to limit radial loading.

A radial load on an actuator is the force that acts perpendicular to the direction of motion or the actuator's axis. The actuator moves in a straight line, and a radial load pushes (or pulls) sideways against it rather than along the direction it is moving. Too much radial load (caused by unlevel positioning) can cause wear or damage to the actuator over time.

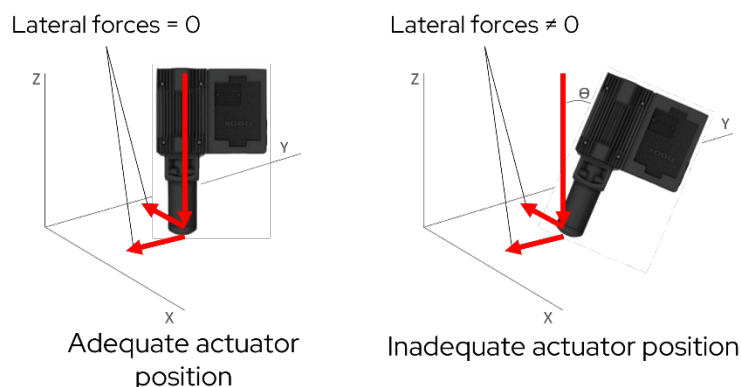

2.4 Level Surface

All actuators must be level on the same flat surface for optimal operation. Actuators set at different levels could result in premature wear.

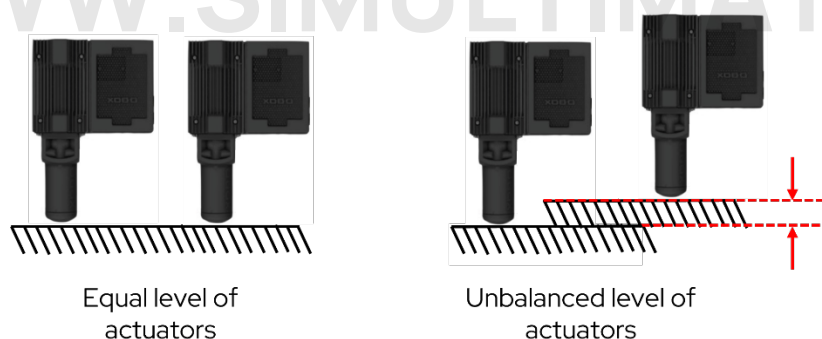

2.5 Weight Distribution

Each actuator has a 250-lb maximum payload. When integrating the haptic system on a platform, D-BOX recommends balancing the **center of gravity** (CG) of the platform to ensure **each Haptic Actuator supports an equal load**. The following figures are examples of equal weight distribution with two, three and four actuators.

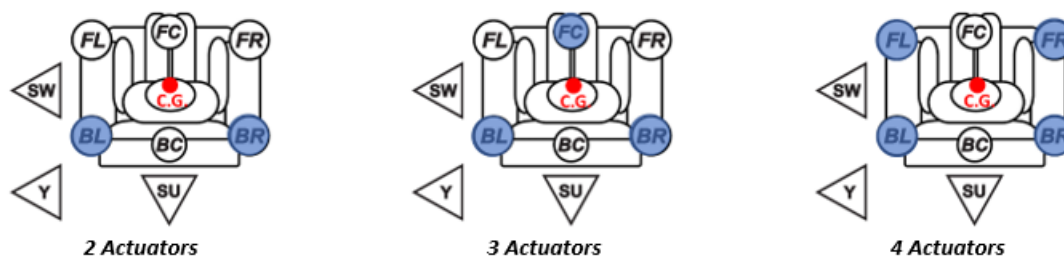

3. VOLTAGE SELECTION

Set all Haptic Actuators to meet your region/country's power voltage by using the switch selector located under the casing.



NOTE: The Haptic Bridge has a universal power supply supplied by D-BOX.

4. HAPTIC ACTUATOR ENDING INSTALLATION

G5 Haptic Actuators come with a non-captive ending.

Captive endings are required when you want to bind the actuators to the floor or a sub-frame.

4.1 Non-Captive Ending Installation (Optional)

Once the Haptic Actuators are installed on your platform, lower the actuators and pivot (for 2-actuator configurations) into the provided metal cups. The actuators and the pivot must be centered into their respective cups.



4.2 Captive Ending Installation

The D-BOX captive ending is made up of a 2-component assembly: a Ball Joint and a Spacer Retainer.

The Ball Joint is used to attach the actuator to the ground (or sub-frame) and allows for slight movement in all directions.



Ball Joint



Spacer Retainer

4.2.1 Spacer Retainers

The Spacer Retainer allows for specific movements of the ball joint on both X and Y axes, eliminating any constraints to platform movement. There are two models of Spacer Retainer (for one or two axes). All Spacer Retainers can be fitted to any model of ball joint.

1 axis: Allowing movement only on 1 axis (X or Y)

2 axes: Allowing movement on 2 axes (X and Y)

WWW.SIMULTIMATE.EU

Spacer Retainer Configurations



2 x Haptic Actuators
and front Pivot



3 x Haptic Actuators



4 x Haptic Actuators

CAUTION: Always respect the orientation of the Spacer Retainer to avoid any damage to the haptic system.

To help with positioning, "OUTWARD" is marked on its top surface.

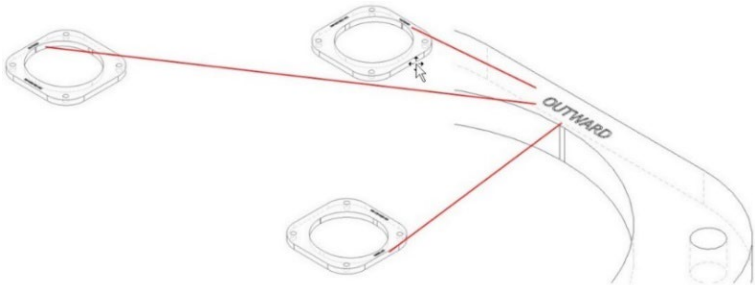

NOTE: The Base Plate (including the Spacer Retainer kit) must be installed at the bottom of the assembly. This allows the captive ending to slide properly.

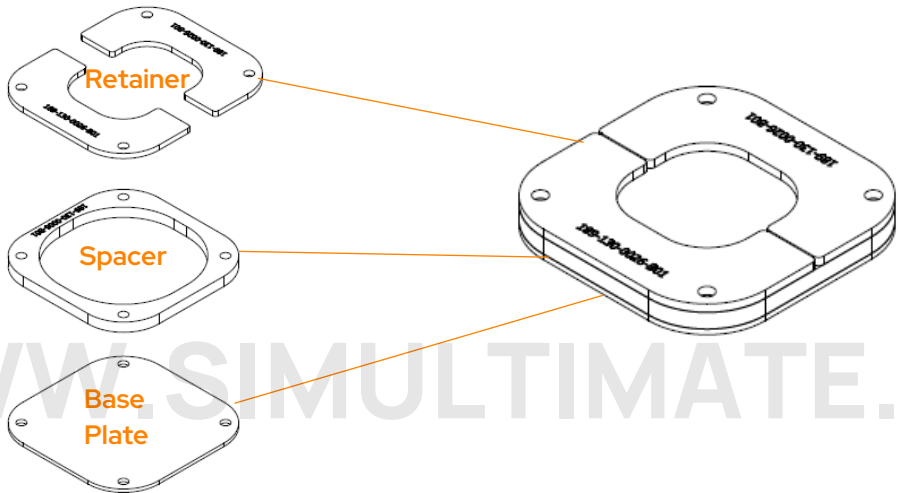

2 or 3 Haptic Actuators

The captive endings must be installed off-center from the Spacer Retainers with the gap at the "OUTWARD" marker.

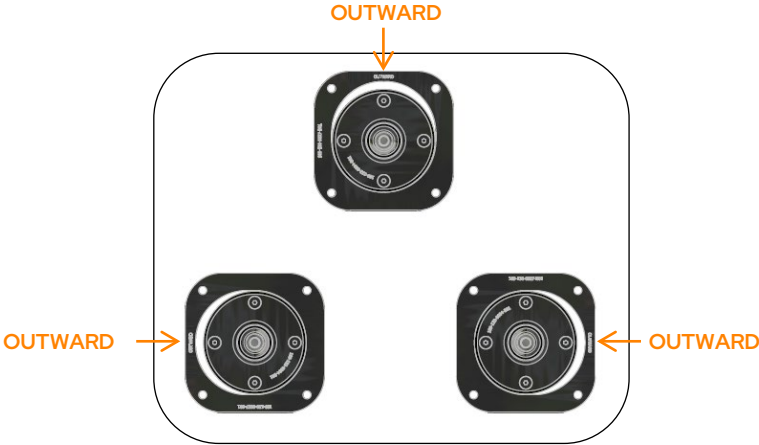

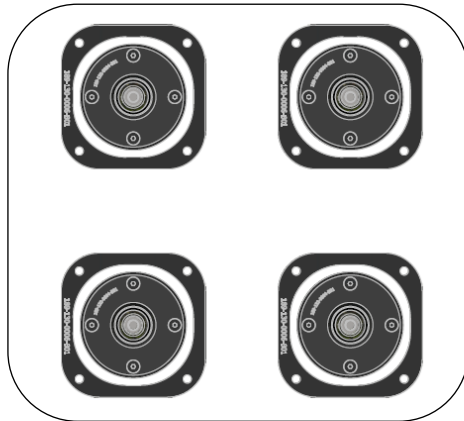

4 Haptic Actuators

The captive endings must be installed in the center of the Spacer Retainers.

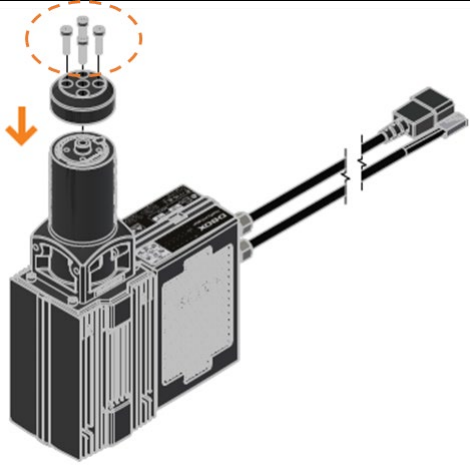
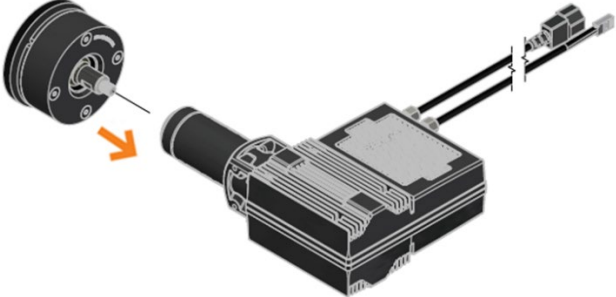
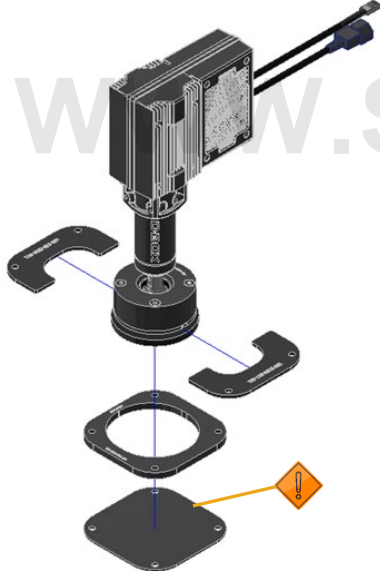

4.2.2 Installation

	 <p>Never operate a Haptic Actuator without the actuator tip/leg installed. This may lead to irreparable damage.</p>
	<p>STEP 1: Remove the existing actuator tip/leg by removing the two (2) screws using a 4mm Allen key.</p>

	<p>STEP 2: Attach the piston adaptor with the four (4) screws provided. Apply some blue thread locker to the screw threads and then torque them to a value of 100 lbf·in (11 Nm) using a 4mm Allen key.</p>
	<p>STEP 3: Apply some blue thread locker to the ball joint threads and then tighten with a torque of 130 lbf·in (15 Nm) using a 5/8" (16 mm) wrench.</p>
	<p>STEP 4: Install the ball joint assembly to the Spacer Retainer and then attach it to the floor (or sub-frame) with adequate hardware (e.g. anchors, bolts, etc.), which is not included.</p> <p> Never operate a Haptic Actuator without the back plate installed. This may lead to malfunction or damage.</p>

5. BRACKET INSTALLATION

D-BOX offers two types of brackets: “L” and “U”-shaped. The screws to attach your Haptic Actuator to a bracket are included; however, you need to provide the screws to mount the brackets to your platform.

5.1 U-Bracket Installation

First, install the U-Bracket to the platform and then attach the Haptic Actuators to the brackets using the screws provided.

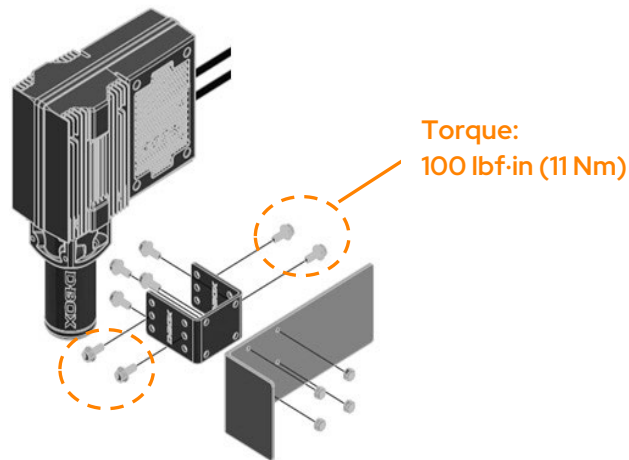

NOTE: Screws to attach the bracket to the platform are not included.

5.2 L-Bracket Installation

First, install the L-Bracket to the Haptic Actuators using the screws provided and then attach the assembly to the platform.

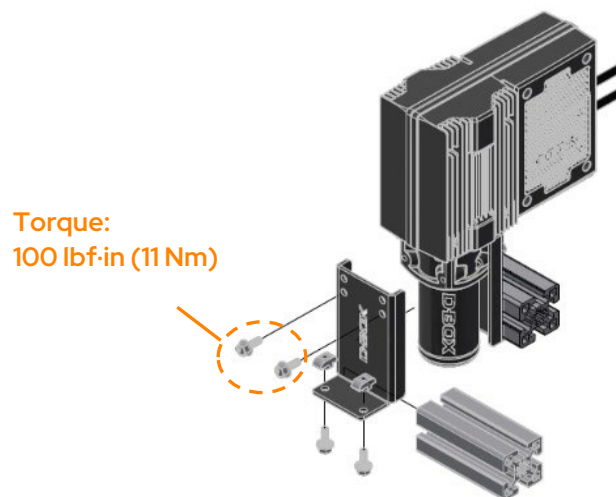

NOTE: Screws to attach the bracket to the platform are not included.

6. CONNECT YOUR HAPTIC SYSTEM

This section contains wiring diagrams for all standard haptic actuator configurations (one to four Haptic Actuators).

Haptic Actuators must be connected in a specific order to ensure proper system operation. Ensure to choose the appropriate diagram (corresponding to your setup).

Although they are optional, we strongly suggest installing the IEC plug lock inserts that prevent power cables from being disconnected. Slide the insert into the IEC female connector (seen in yellow).



The Haptic Bridge must be connected directly to your computer (USB port). Using an external USB hub may create haptic interruption and/or system error.

Home theater configurations are available in the [HaptiSync System User Manual](#).

NOTE: *If you have a system mixing G5 and G3 haptic systems, please refer to [Appendix A](#).*

6.1 1-Actuator Configuration

Configure your system using [D-BOX System Configurator](#).

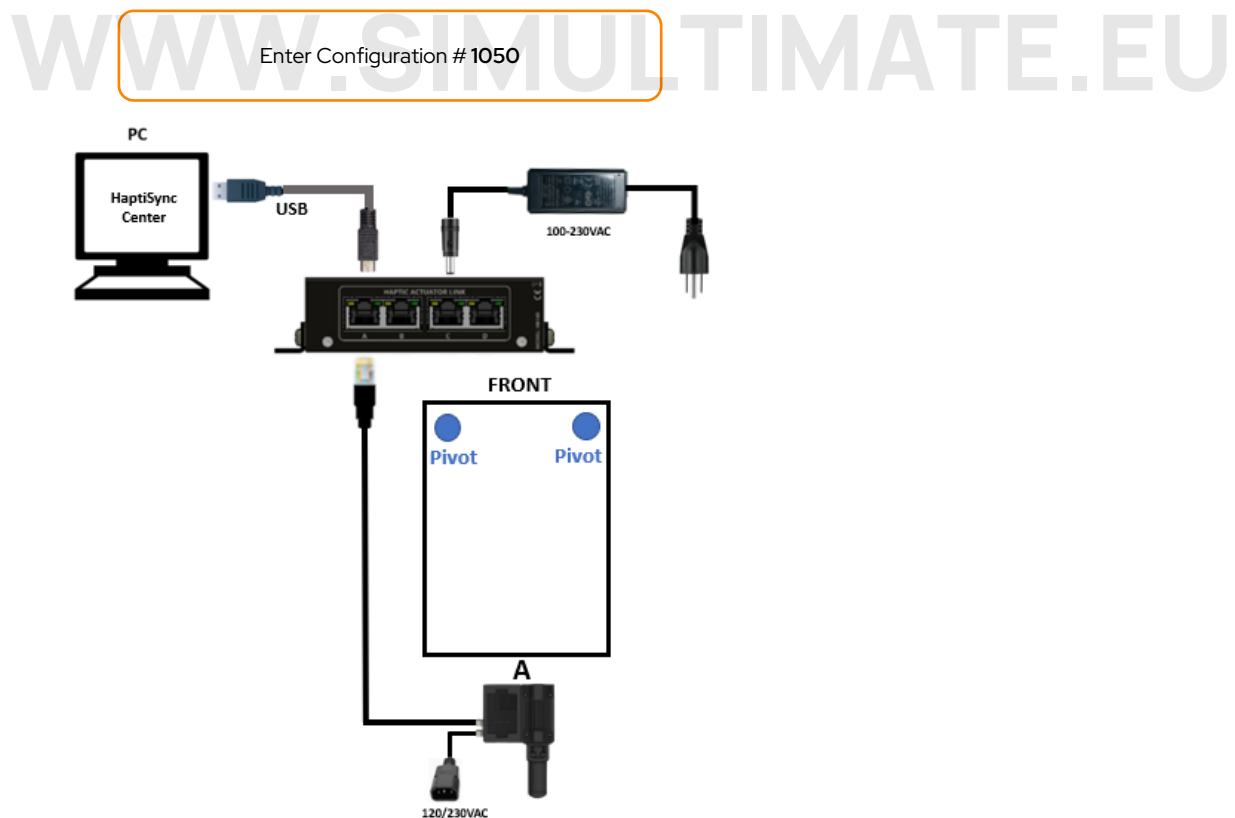

6.2 2-Haptic Actuator Configuration

Configure your system using [D-BOX System Configurator](#).

Enter Configuration # 10721

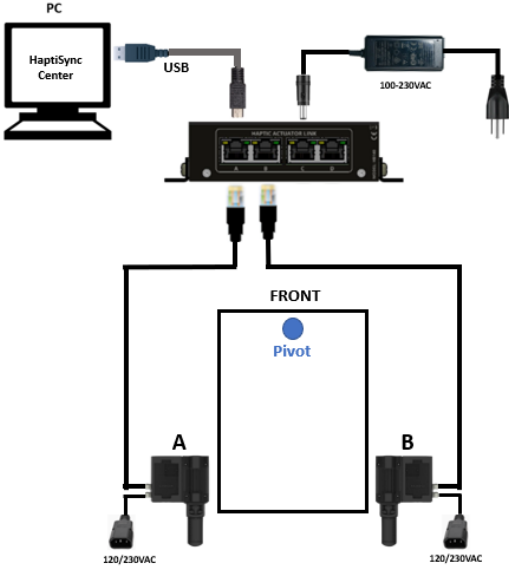

Enter Configuration # 10719

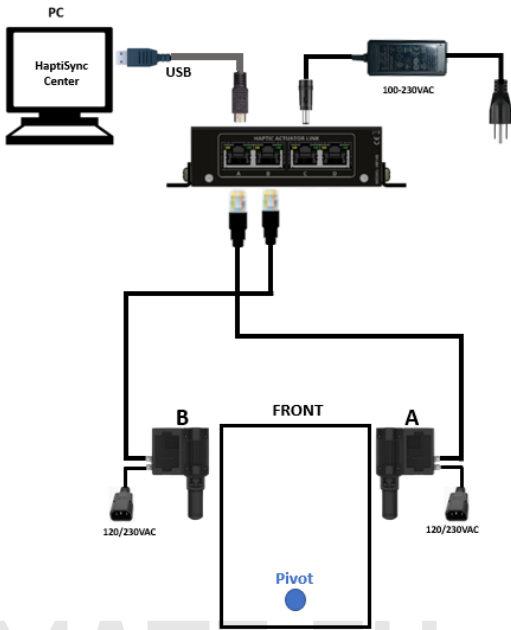

OR

WWW.SIMULTIMATE.EU

6.3 3-Haptic Actuator Configuration

Configure your system using [D-BOX System Configurator](#).

Enter Configuration # 10733

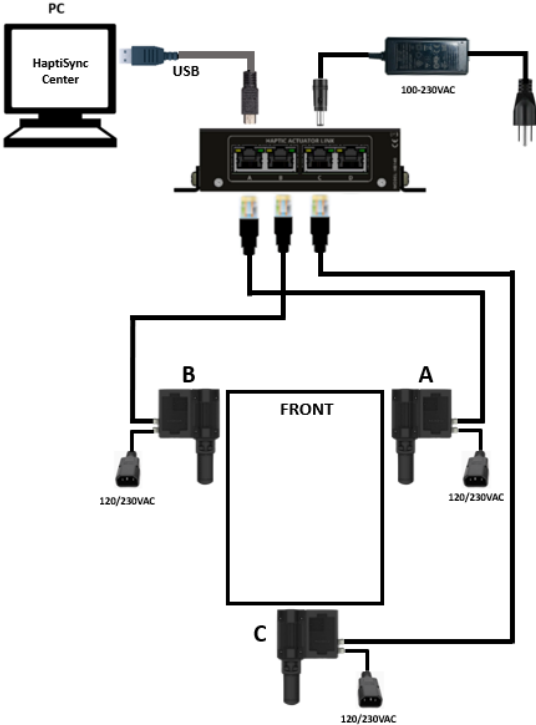

Enter Configuration # 10731

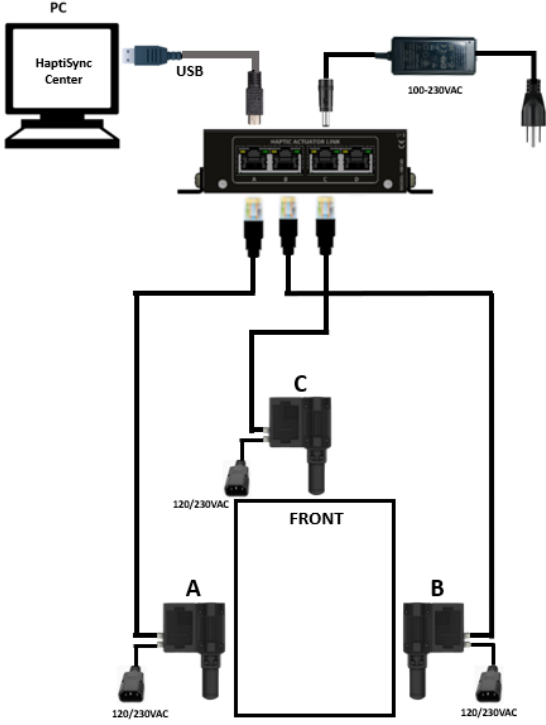

OR

6.4 4-Haptic Actuator Configuration

Configure your system using [D-BOX System Configurator](#).

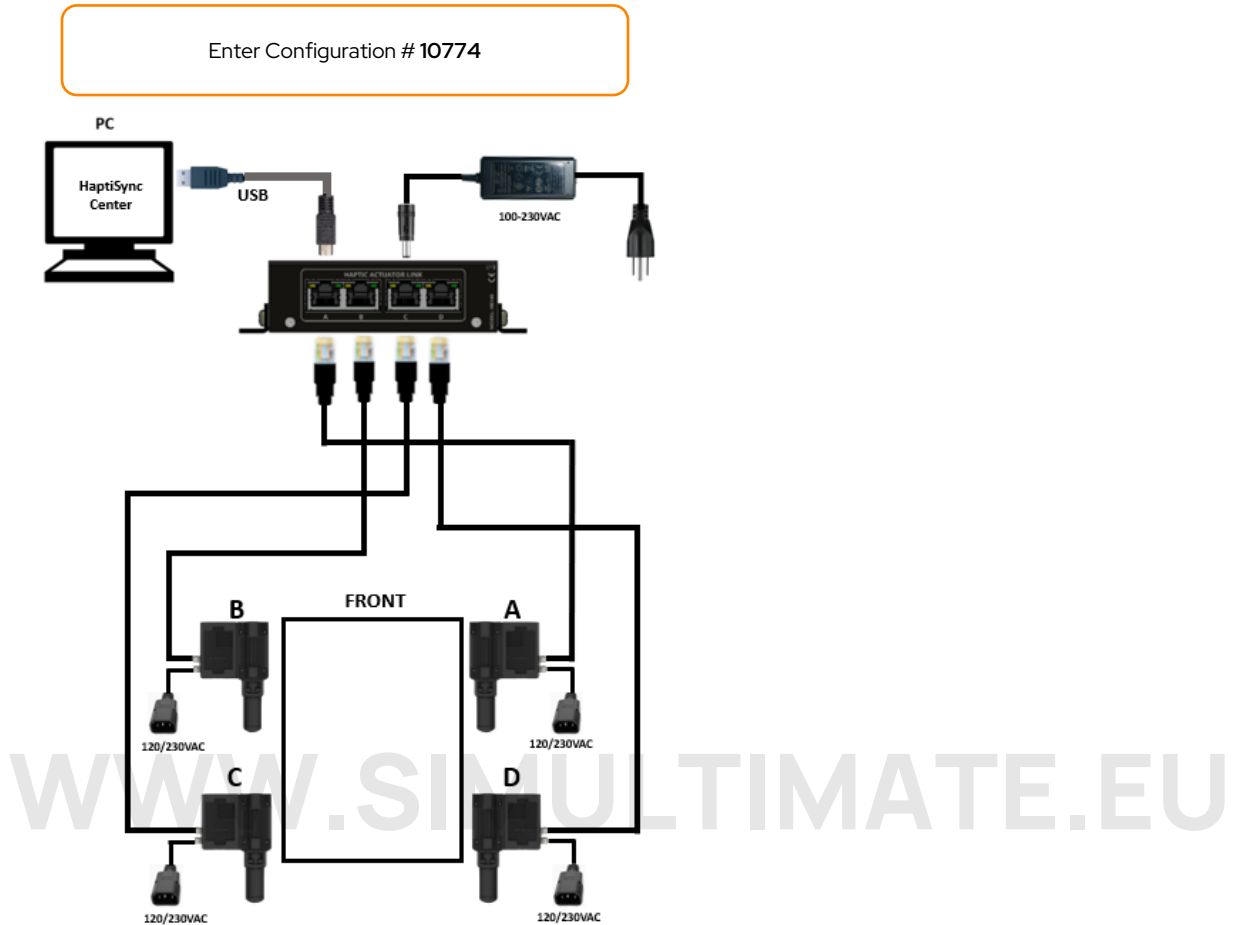

6.5 Haptic Expander

For configurations requiring more than four Haptic Actuators, you must use a D-BOX Haptic Expander (HX4) to increase the number of ports from the Haptic Bridge (HB140 or HB240).

D-BOX Haptic Expander (HX4)

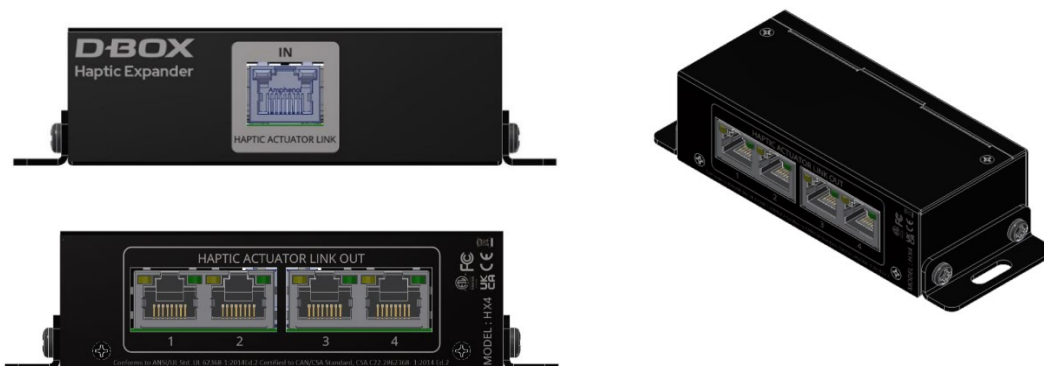



The Haptic Expander must be connected to port **A** of the Haptic Bridge. The first four (4) Haptic Actuators must be connected to the HX4. The following actuators are connected to ports **B**, **C**, and **D** of the Haptic Bridge, depending on the number of actuators. For an 8-actuator configuration, the Haptic Expander must be connected to ports **A** and **B** of the Haptic Bridge.

6.5.1 5-Actuator Configuration

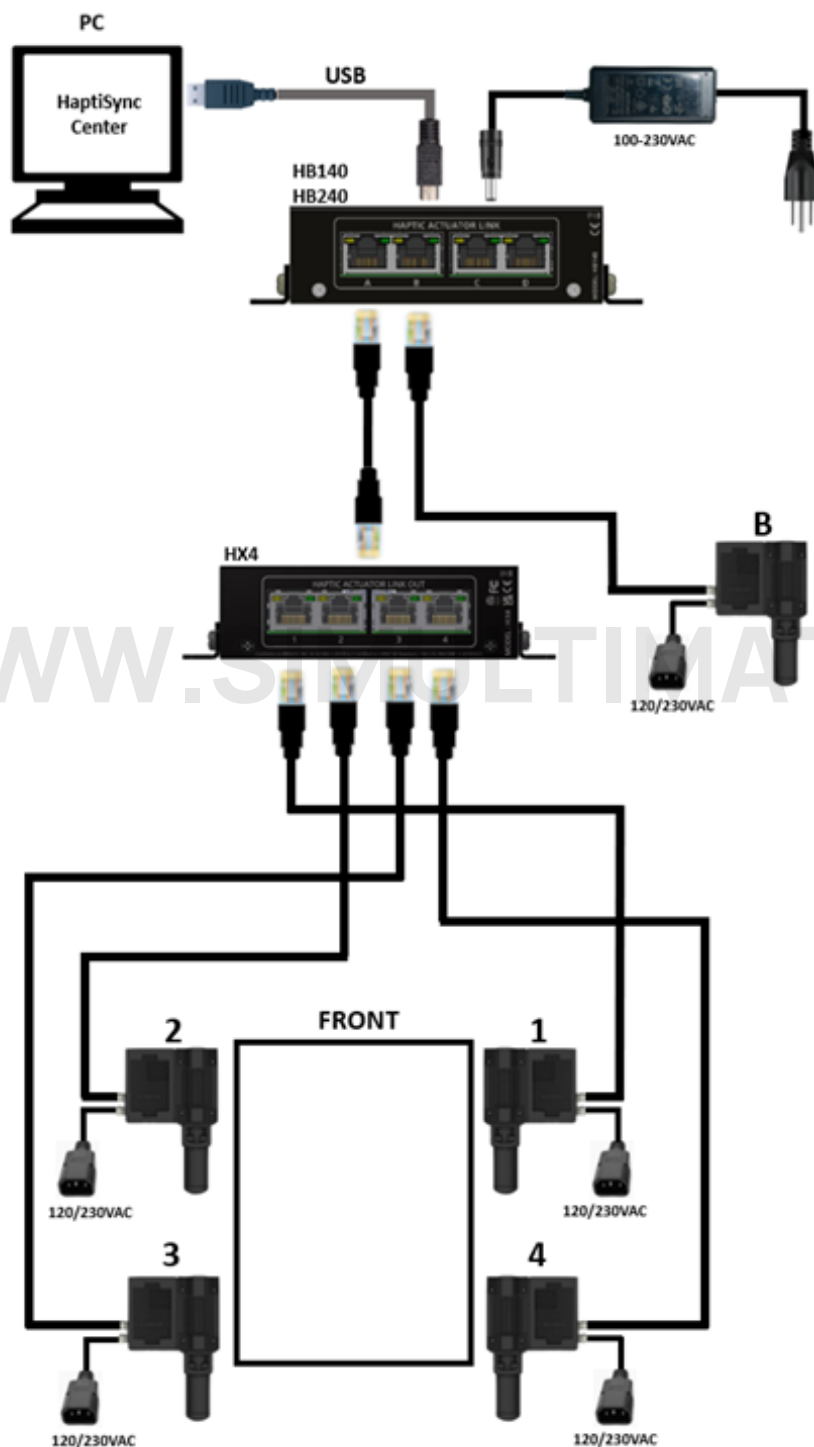

WWW.SIMULTIMATE.EU

6.5.2 6-Actuator Configuration

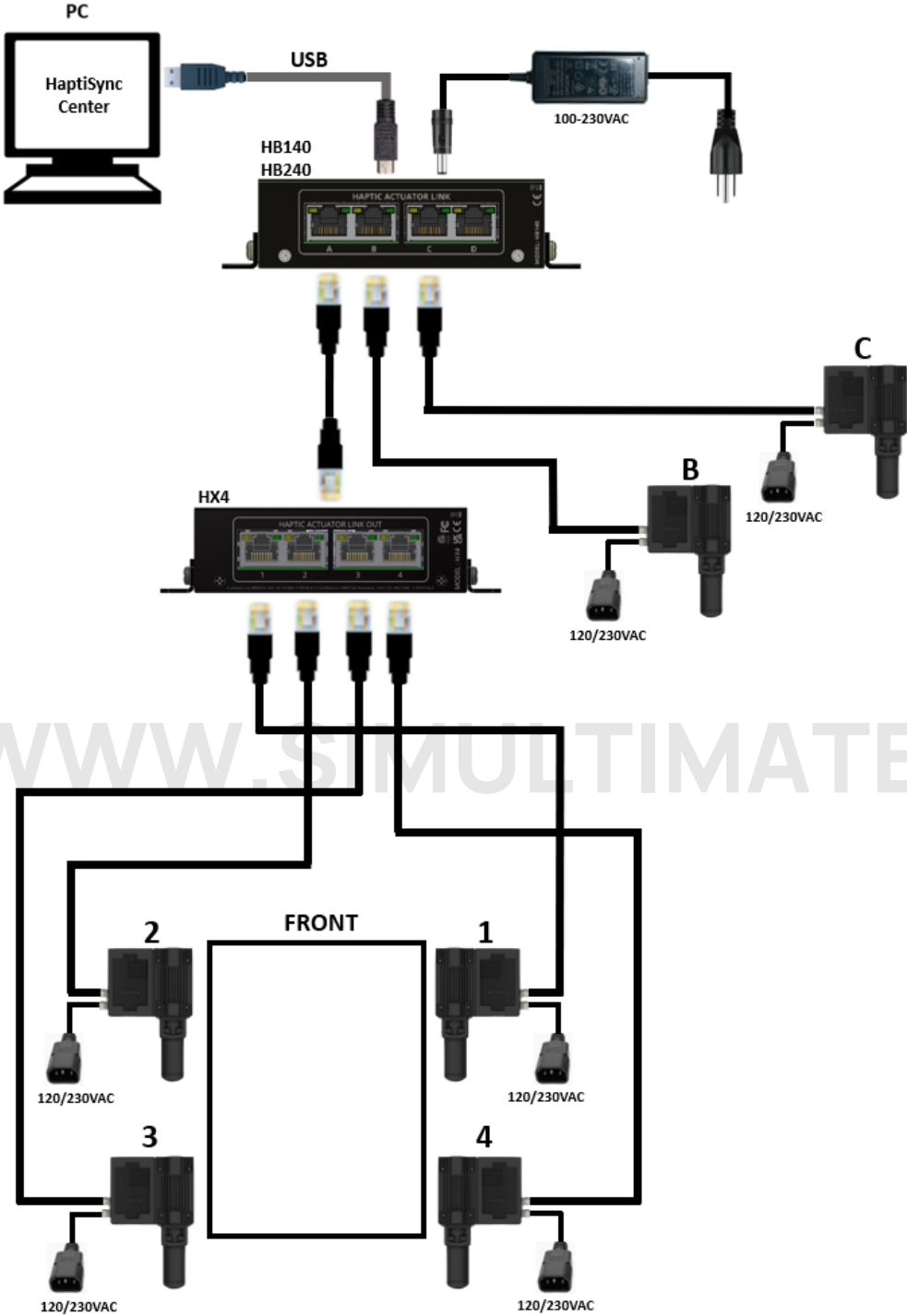

6.5.3 7-Actuator Configuration

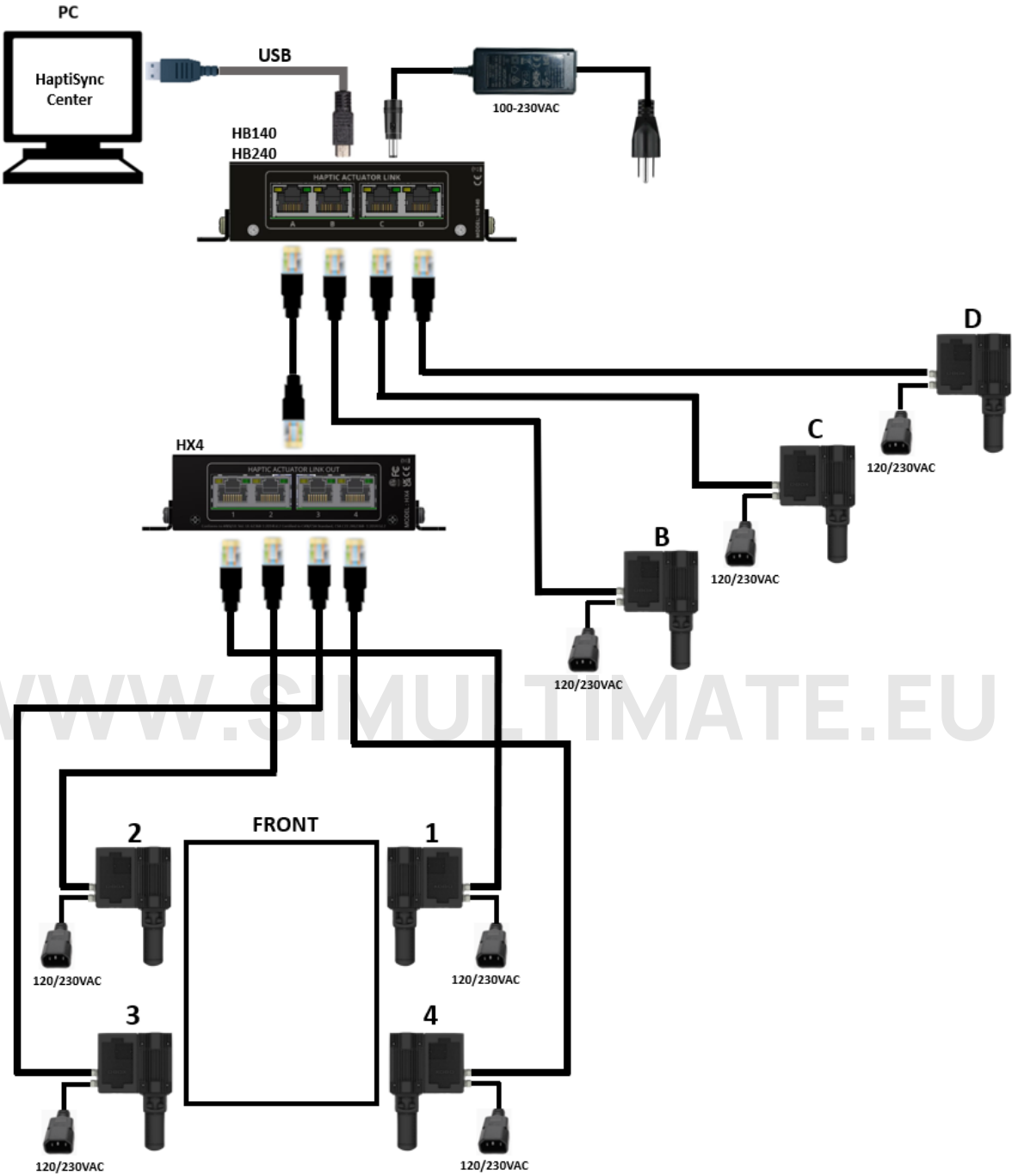

6.5.4 8-Actuator Configuration

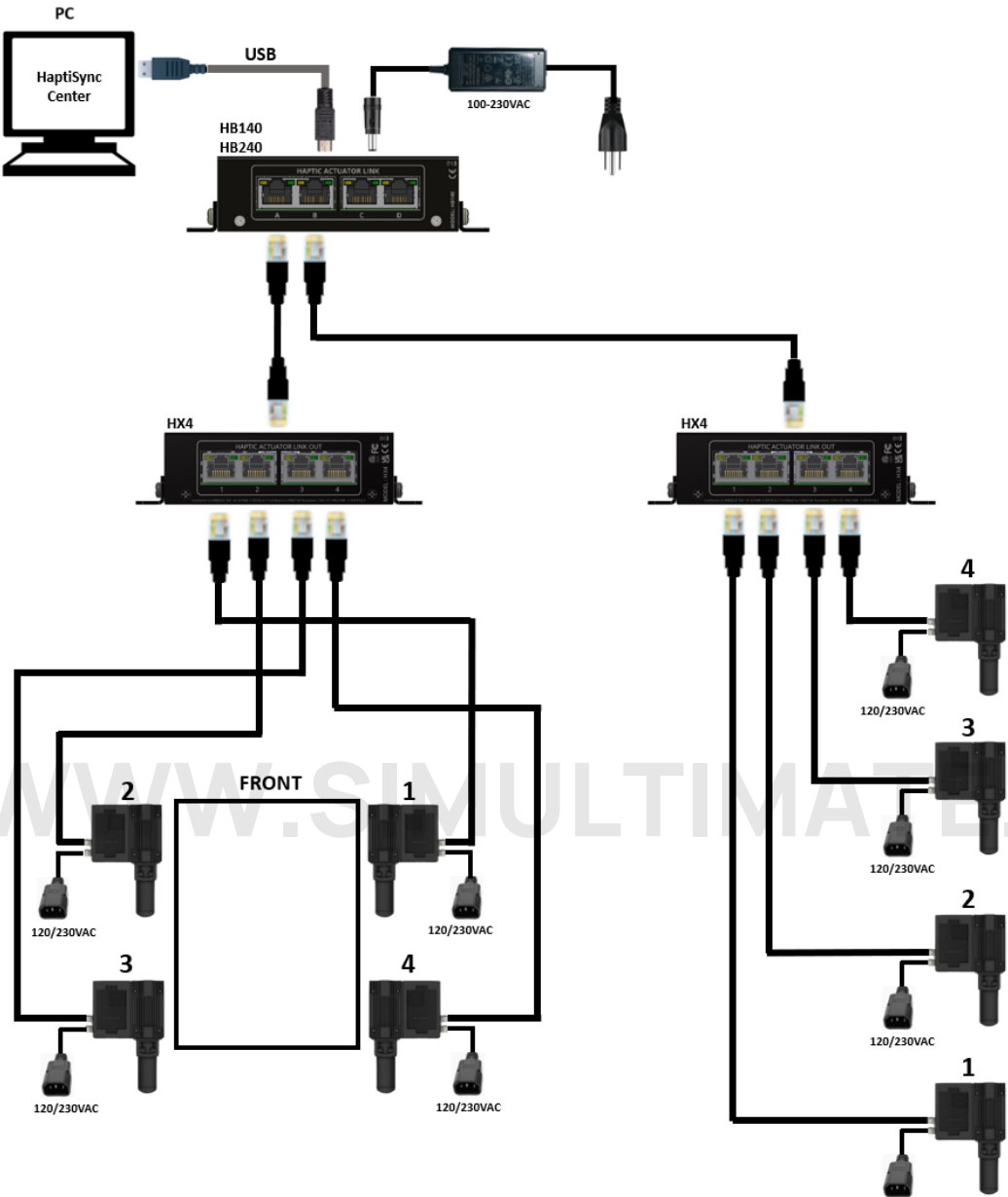

7. CREATE YOUR D-BOX CONNECT ACCOUNT

A [D-BOX Connect account is required](#) to install and update haptic codes for D-BOX Coded Games and access haptic codes for movies. Follow the on-screen instructions of the D-BOX Connect webpage to create your account.

8. SOFTWARE INSTALLATION

There are two (2) D-BOX software packages to install: [D-BOX HaptiSync Center](#) and [D-BOX System Configurator](#). Both are available on our [website](#).

8.1 Minimum System Requirements (PC)

- Microsoft Windows 10 x64 (1809 or later) or Windows 11
- 512 MB of free RAM for D-BOX Coded Gaming and an additional 1 GB if using D-BOX Coded Video mode
- 850 MB of free drive space for D-BOX Coded Gaming and an additional 23 GB for the D-BOX Coded Video haptic library
- USB port 2.0 Full Speed (or faster)

WWW.SIMULTIMATE.EU

9. D-BOX SYSTEM CONFIGURATOR

D-BOX System Configurator is a free software tool for updating and configuring haptic systems.



It is necessary to update and configure your system because it is delivered from the factory with a blank configuration.

System Configurator is compatible with Microsoft Windows 7, 8, 10, and 11 - 64 bit.

STEP 1: Download [D-BOX System Configurator](#).

STEP 2: Extract the compressed file and run the installer.

NOTE: The D-BOX System Configurator User Guide is available in the included D-BOX folder.

STEP 3: Update your firmware:

- a) Ensure your haptic system is powered on and open D-BOX System Configurator (from the D-BOX folder).
- b) From the Firmware Update tab, click **Refresh Firmware Status**.
- c) If the system display reads “*Outdated (Update firmware)*”, click **Update Firmware** and follow the instructions.

WWW.SIMULTIMATE.EU

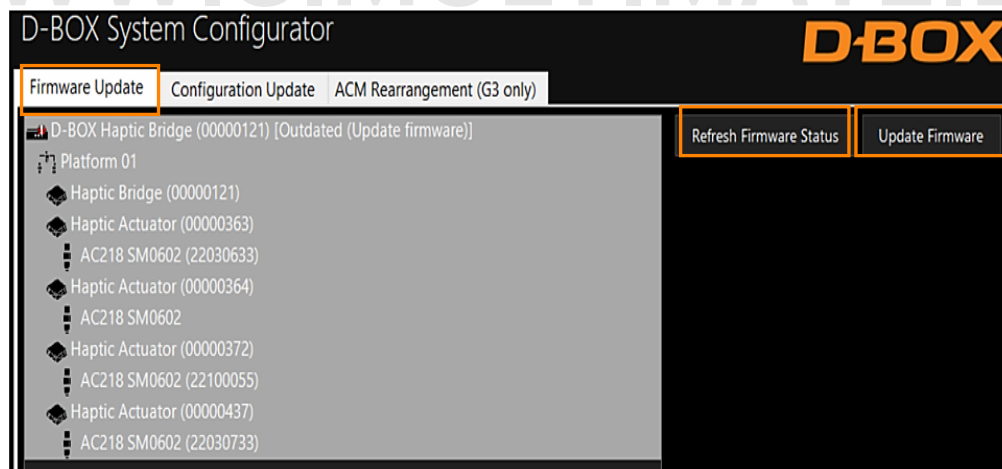

STEP 4: Update the Configuration.

The Configuration Update allows you to configure your haptic system (actuator positions and axes (Degrees of Freedom - DOF)):

- a) Select the Configuration Update tab and click **Refresh Information**. Ensure the Actuator Count matches with your system. If not, make sure that all power cables and the RJ45 cable are firmly connected.

- b) Enter the configuration number matching your system (see [Connect Your Haptic System](#)) or select the axes you want for your system.
- c) Once the configuration is selected, click **Apply Configuration** and confirm to start the configuration update process, then follow the instructions.

D-BOX System Configurator

Firmware Update | **Configuration Update** | ACM Rearrangement (G3 only)

Hardware Selection
 Communication Device: D-BOX Haptic Bridge (00000501) | Platform: 1

Actual DOF Configuration
 Configuration: 10774 | Axes: Roll ✓, Pitch ✓, Heave ✓, Yaw, Surge, Sway

DOF Configuration Filter
 Interface Count: 5 | Actuator Count: 4 | Configuration: | Axes: Roll, Yaw, Pitch, Surge, Heave, Sway

Compatible Configuration Selection

Actuator	Assignment	Position
D	Roll, Pitch, Heave	Front Right
G	Roll, Pitch, Heave	Front Left
J	Roll, Pitch, Heave	Rear Left
M	Roll, Pitch, Heave	Rear Right

Configuration | Description
 10774 | RPH - 4 Actuators - 5 Intf (M, S-FR0, S-FL0, S-BL0, S-BR0)

Apply Configuration | Refresh Information

Execution Details

10.D-BOX HAPTISYNC CENTER

D-BOX HaptiSync Center is an application to manage all experiences enabled by your D-BOX haptic system. This software package includes the system’s driver in addition to the following software and utilities:

- D-BOX HaptiSync Center
- D-BOX Adaptive Gaming Configurator
- D-BOX System Monitor Recorder
- D-BOX Stimuli Presenter

You can download it from our [website](#). After downloading, simply follow the on-screen instructions to install the software.

Select your haptic experience from the HaptiSync Mode section.

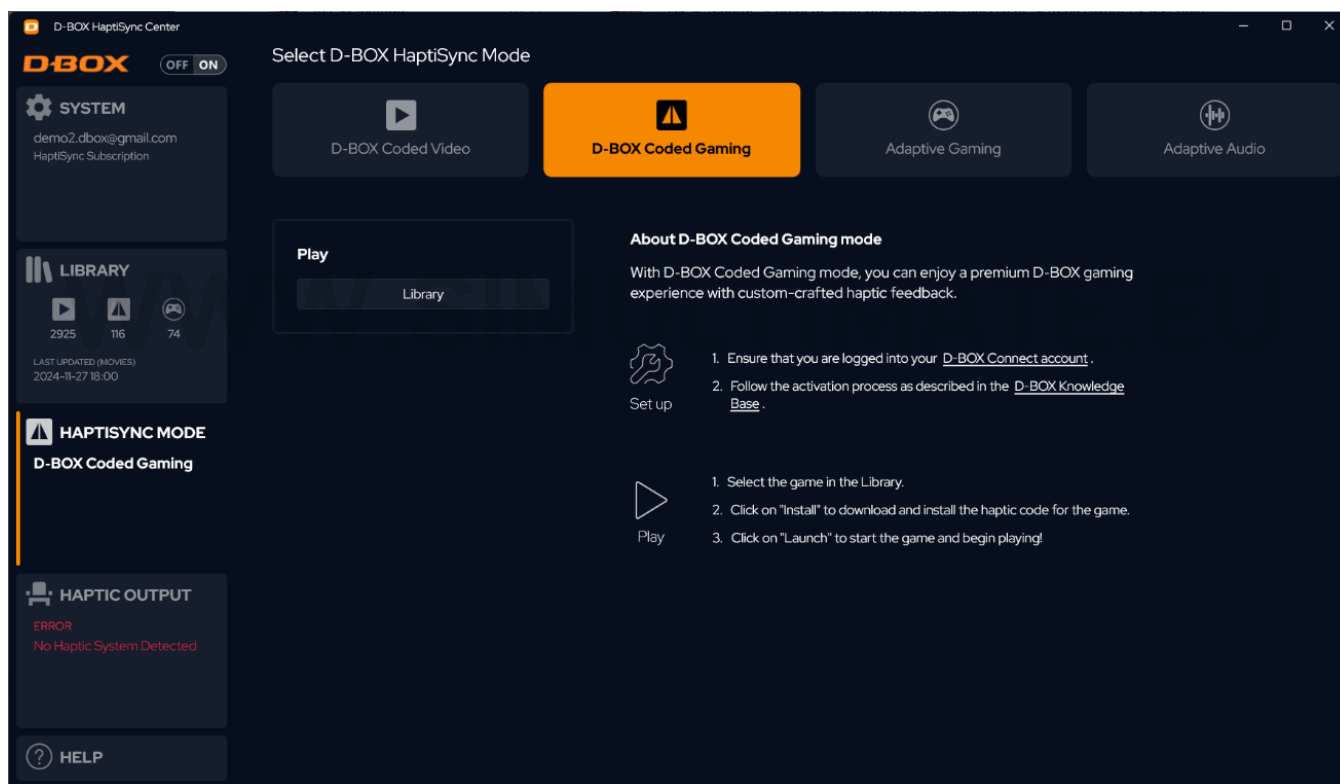

D-BOX Coded Gaming	Premium haptic experiences for D-BOX-coded apps, simulators and games. Use Adaptive Gaming mode for titles not listed. For detailed instructions, visit: https://support.d-box.com/en/knowledge/hsc-dbox-coded-gaming
D-BOX Coded Video	Premium haptic experiences for D-BOX-coded movies and TV shows using audio synchronization. For detailed instructions, visit: https://support.d-box.com/en/knowledge/hsc-dbox-coded-video
Adaptive Gaming	Haptic experiences using real-time events, triggered by game controller or keyboard. For detailed instructions, visit: https://support.d-box.com/en/knowledge/hsc-adaptive-gaming
Adaptive Audio	Automated haptic experiences for any movie, music, TV show, or game using audio processing. For detailed instructions, visit: https://support.d-box.com/en/knowledge/hsc-adaptive-audio

10.1 Haptic Output Tab

The Haptic Output tab in HaptiSync Center provides essential tools for monitoring and managing your haptic system. It includes three sub-tabs: Settings, Status, and Diagnostics—each offering specific functions to ensure optimal performance and assist with troubleshooting.

10.1.1 Settings Tab

Contextual tooltips provide high-level information for these settings. Please refer to our [Knowledge Base](#) for more details. The following settings apply to all games on your computer.

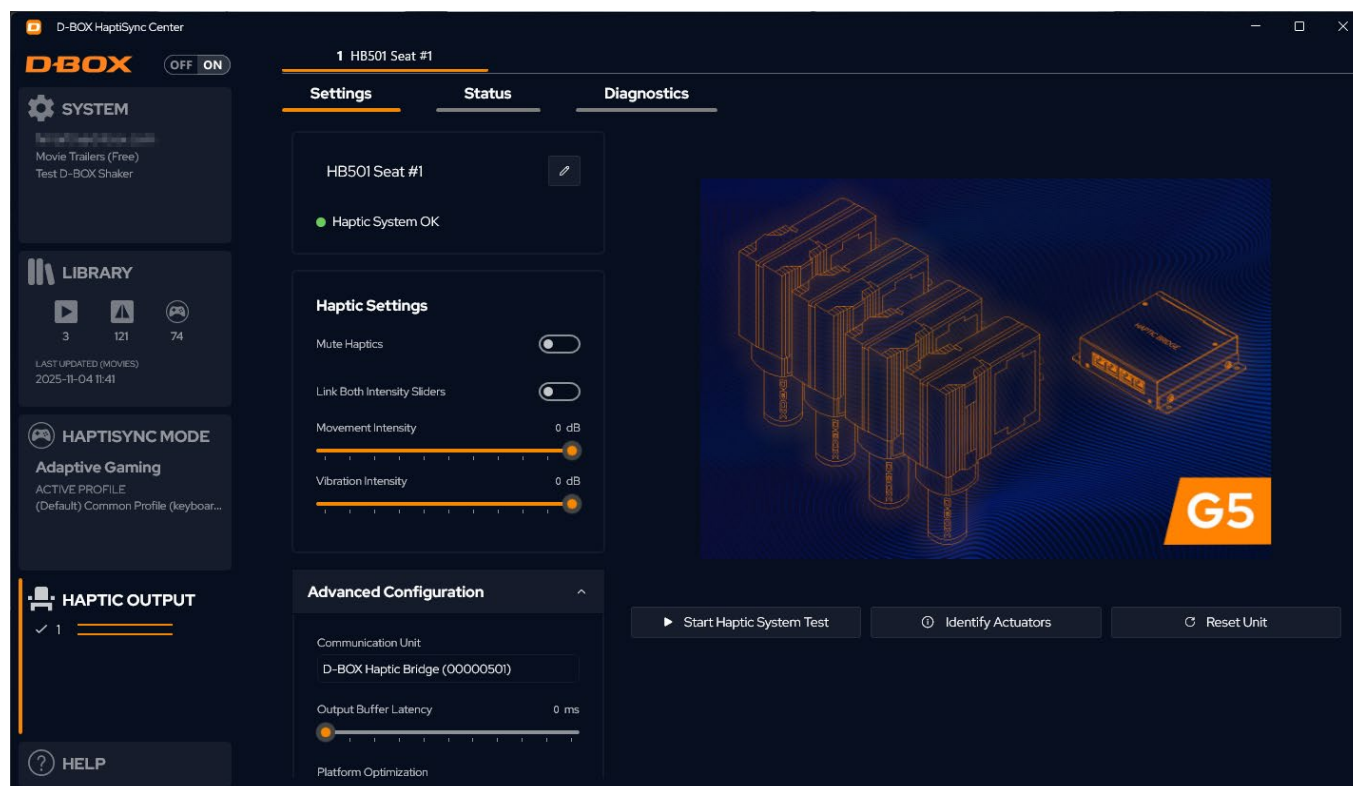

10.1.2 Status Tab

The Status tab displays the status of each component in your haptic system. All indicators should be green. Haptic Actuators in a Transition state are displayed as orange. Haptic Actuators in an Alarm state are displayed as red.

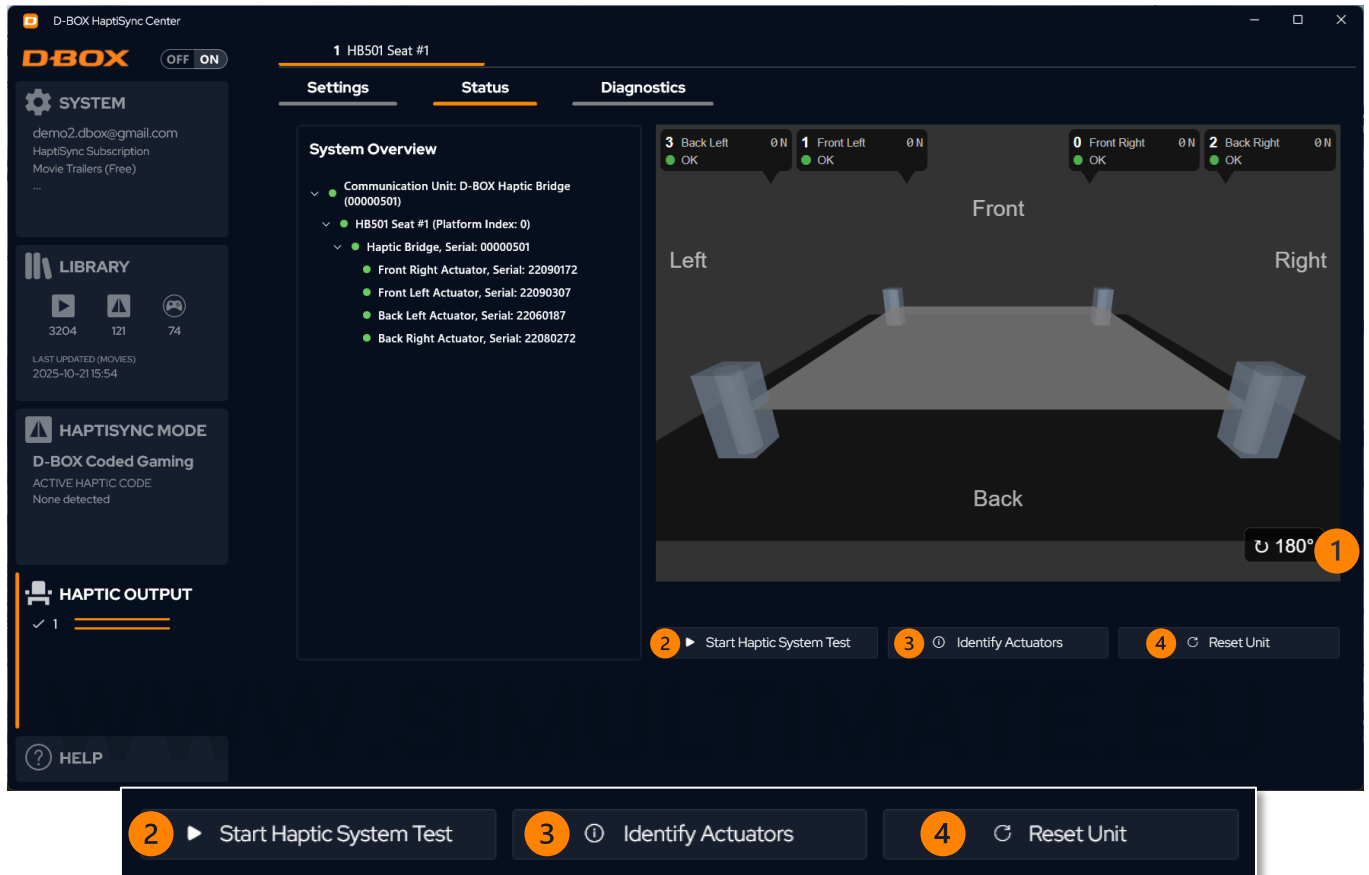

- 1 Use the **Rotate 180°** button to change the orientation of the 3D platform view.
- 2 Use the **Start Haptic System Test** button to test the hardware–software communication of the system by generating movement and vibration in a preset pattern.
- 3 Use the **Identify Actuators** button for interactive testing that validates that all actuators are located as expected on the platform.
- 4 Use the **Reset Platform** button to reset the D-BOX haptic system. Reset all your actuators to neutral (The platform will perform a homing sequence).

10.1.3 Diagnostics Tab

Displays real-time health status of the haptic system. If a component fails, related information appears in red as a fault.

The screenshot shows the D-BOX HaptiSync Center interface. The 'Diagnostics' tab is active, displaying a table of system parameters. A red box highlights the 'Actuator Back Right' status, which is labeled 'Fault'. A callout box on the right side of the screen provides details for this fault: 'Actuator Back Right', 'Fault', 'Connection Port 4', and 'Haptic Actuator 2 AC218 SM0602'. A red box at the bottom of the callout is labeled 'Fault Example'.

Overall State	Comm Unit	ACM 0	Actuator Front Right	Actuator Front Left	Actuator Back Left	Actuator Back Right
Fault (s)	OK	OK	OK	OK	OK	OK

NOTE: See [Faults and Corrective Actions](#) for possible causes and corrective actions.

10.2 D-BOX Adaptive Gaming Configurator

This application allows you to build, modify, and activate your Adaptive Gaming profiles. You can also share your favorite profiles with other D-BOX users by right-clicking the profile and selecting the Export function.

The screenshot shows the D-BOX Adaptive Gaming Configurator interface. The 'Elden Ring (action adventure, gamepad)' profile is selected and active. The interface displays various controller settings, including 'Generic Controllers' (MS Mouse, KB Keyboard, GC Gamepad Controller) and 'Joystick Controllers'. The 'Movement - Joystick' section is expanded, showing settings for 'Player Velocity' and 'Footsteps Ambience'. The 'Action - Continuous' section is also expanded, showing settings for 'Shield Up' and 'Light Attack (1 Handed Axe)'. The 'Haptic Output' is enabled, and the 'Adaptive Profile Selector' on the left lists various game profiles.

10.3 D-BOX System Monitor Recorder

This is a useful tool for troubleshooting your haptic system. The System Monitor Recorder lets you export logs, helping our Support team diagnose and resolve issues:

STEP 1: Power off all ACM(s) or G5 Haptic Bridge(s) by disconnecting their power cords.

STEP 2: Open the D-BOX System Monitor Recorder from the D-BOX Utilities folder and let it run in the background.

STEP 3: Power on the ACM(s) or G5 Haptic Bridge(s).

STEP 4: Run the simulation or game software until the issue is reproduced.

STEP 5: Once the issue is reproduced:

a) Click **Save Recording** to save the recording file.



b) Click **Take Snapshot**.



c) Save both files using the default names to simplify the identification process.

STEP 6: Send both files by email to [D-BOX Support](#).

10.4 D-BOX Stimuli Presenter

The D-BOX Stimuli Presenter is a keyboard-controlled application used for testing and demos, sending basic signals to the haptic system.

```

D-BOX Stimuli Presenter
Initializing...
Started

Travel time: 1.0 s.
Ambiance and effect intensity: 0 dB
=== PRESENTER MENU ===

Roll/Pitch TRAVEL DIRECTION   Heave TRAVEL DIRECTION   TRAVEL DURATION
Left /\ Right                Up
[7] [8] [9] Forward         /\
<- [4] [5] [6]-> Center     arrows                    [-] Decrease
[1] [2] [3] Backward        \/\                      [+] Increase
                               \/\
                               Down

[T][Y] Gun effect (front)    [B] Boat ambiance        EFFECT INTENSITY
[G][H] Gun effect (back)    [C] Climb ambiance
[E] Explosion effect        [R] Rumble ambiance     [/] Decrease
                               [*] Increase

[I] Sine Generator          [U] Decrease Frequency
[L] Stop ambiances         [O] Increase Frequency
[Q] Quit
    
```

11. HAPTIC SYSTEM OPERATION

Power on your haptic system. The Haptic Actuators should do a homing sequence going all the way up, all the way down, and then center. This is normal behavior.

12. TROUBLESHOOTING

This section contains step-by-step instructions to troubleshoot your G5 haptic system. If you need additional support, contact your reseller support team or the D-BOX Technical Support team if your system was bought directly from D-BOX.

12.1 Initial Troubleshooting Steps

STEP 1: Verify that all Haptic Actuators are set to your [country/region's voltage](#).

STEP 2: Make sure your Haptic Actuators are connected to a grounded electrical outlet. If you must use an extension cable, use a 3-wire cable with properly grounded plugs. **Do not connect to a circuit with a GFI breaker.**

STEP 3: Make sure that all power and network cables are firmly plugged in.

STEP 4: Verify that your Haptic Actuators are connected to the right ports of the [Haptic Bridge](#).

STEP 5: Do a visual inspection of your setup to ensure that there is nothing to prevent the haptic system from moving properly. Power cords and network cables must be secured and away from the Haptic Actuators' path.

12.2 Reinitiate Your Haptic System

STEP 1: Reset the entire system:

- a) Reboot your computer.
- b) Power off the Haptic Actuators as well as the Haptic Bridge by unplugging the power cords. Wait for at least 60 seconds then restore the power to the equipment. The platform should do its homing sequence by going up, down, and then into the middle position. If the system does not go through its homing sequence, open D-BOX HaptiSync Center, navigate to the Diagnostics tab in the Haptic Output tab and check if there are any alarms (see [Faults and Corrective Actions](#)).

STEP 2: Reset all the global settings—the Haptic Settings and Advanced Configuration drop-downs in the Haptic Output tab, under Settings:

SETTING	VALUE
Haptic Settings	
Mute Haptics	OFF
Link Both Intensity Sliders	OFF
Movement Intensity	0 dB (full)
Vibration Intensity	0 dB (full)

SETTING	VALUE
Advanced Configuration	
Output Buffer Latency	0 ms
Platform Optimization	Automatic Detection
Idle Position	Park
Actuator Layout Rotation	None*
Actuator Stroke	Automatic Detection

*Unless using a G5 Motion Platform (Mercedes-Benz or Mercedes-AMG) for Sim Racing.

STEP 3: Reset the specific motion code settings for the game you are using. When playing a game using the D-BOX Coded Gaming mode, select the game in the Library, and then click **Haptic Settings & Profile Selection**. In the new window, you will find the Global Parameters tab as well as the Motion Profile Editor tab. From the Motion Profile Editor tab, reset all the motion settings.

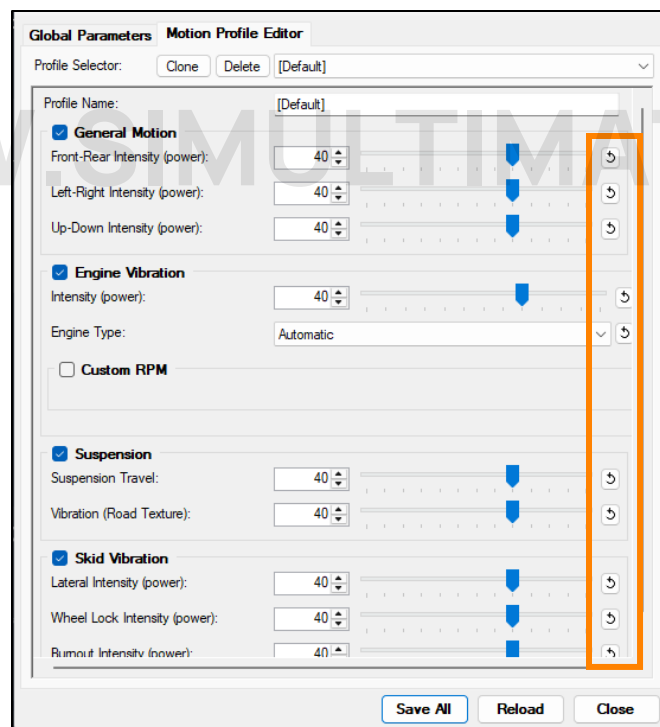

12.3 Update Software and Firmware

STEP 1: Make sure you have the latest version of D-BOX HaptiSync Center installed on your PC. Click the ^ icon, located to the left of the System Tray icons, to open the expanded tray. Right-click the D-BOX Updater icon then select **Check for Updates**.

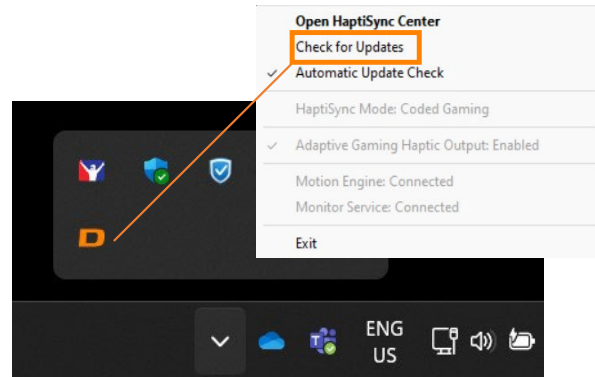

STEP 2: Make sure you have configured (if not done by your dealer) your G5 haptic system using the latest version of the [D-BOX System Configurator](#) software.

WWW.SIMULTIMATE.EU

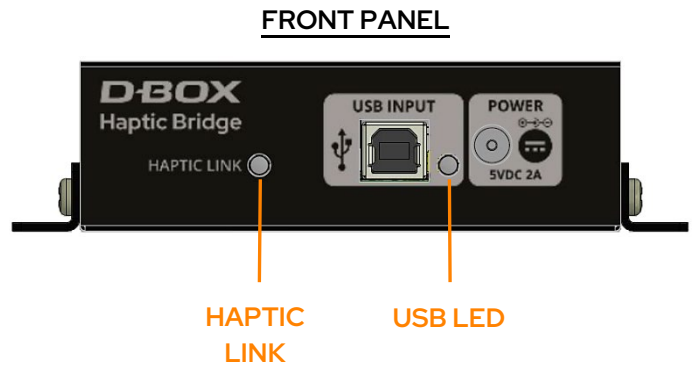

12.4 Troubleshooting with Haptic Bridge LED Statuses

This section covers the status LED of the Haptic Bridge.

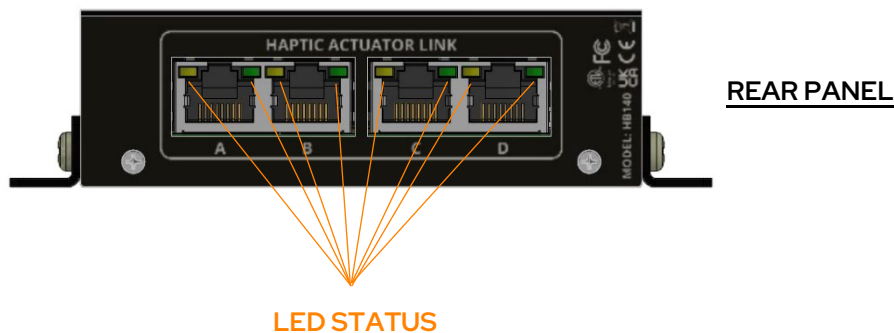

HAPTIC LINK LED	USB LED	STATUS	SOLUTION
○	○	Haptic Bridge is not powered	Make sure the power supply is properly connected.
●	●	No USB connection is detected	<p>Check that the USB cable is properly connected (both ends). Do not use a USB hub.</p> <p>Make sure you are using the original USB cable provided with your controller.</p> <p>Make sure you have the latest version of D-BOX HaptiSync Center installed.</p>
○	○	Unit is ready to operate but the platform is in <i>Park</i>	Make sure the platform is enabled.
●	○	The platform is enabled but no haptic data is sent	USB LED should turn green as soon as you stream haptic data to your haptic system.
●	●	The device is operational and receiving motion data (or silence data)	N/A



LED STATUS	STATUS	SOLUTION
<p>Blinking Amber</p> 	<p>No Motion Player detected / no communication</p> <p>System fault or haptic actuator has not been set to the right voltage</p> <p>Actuator fault</p>	<p>Make sure the USB cable is properly connected (both ends). Do not use a USB hub.</p> <p>Make sure you have the latest version of D-BOX HaptiSync Center installed.</p> <p>Verify that all Haptic Actuators are set to your region's power voltage.</p> <p>Use HaptiSync Center to see the system fault.</p>
<p>Blinking Amber and Green</p> 	<p>Haptic Actuators communication issue</p>	<p>Make sure the Haptic Actuator power and RJ45 cables are properly connected.</p> <p>Make sure the RJ45 cables are connected into the right ports of the Haptic Bridge.</p>
	<p>The system is operational</p>	<p>N/A</p>

12.5 Troubleshooting Hardware Issues (HaptiSync Center)

The Haptic Output tab of HaptiSync Center has the Status and Diagnostics tabs to assist with troubleshooting.

STEP 1: Check the indicators under the Status tab—they should be green. A red dot indicates a faulty component.

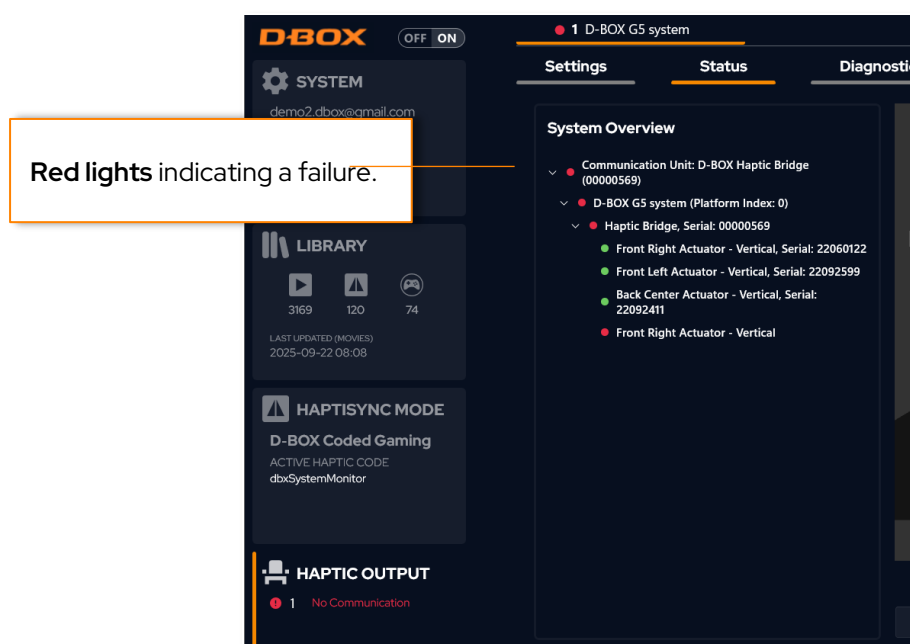

NOTE: Additional functions are available via buttons at the bottom right:

- **Start Haptic System:** Generates movement and vibration using a preset pattern. Useful for testing hardware-software communication.
- **Identify Actuators:** Sends a haptic “knock” to each actuator sequentially with on-screen identification, which helps verify correct actuator positioning.
- **Reset Unit:** Reset all your actuators to neutral. The platform will perform a homing sequence.

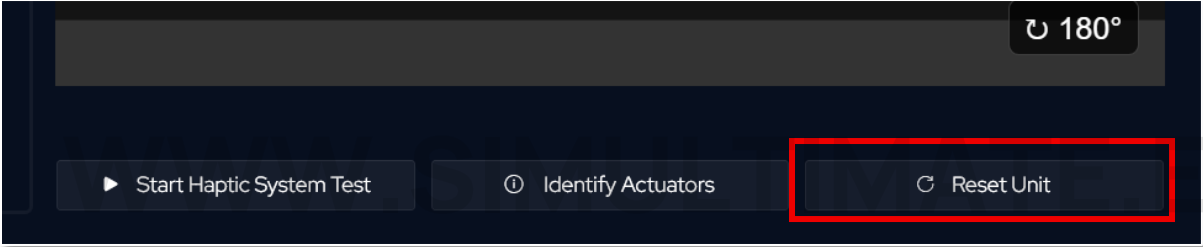
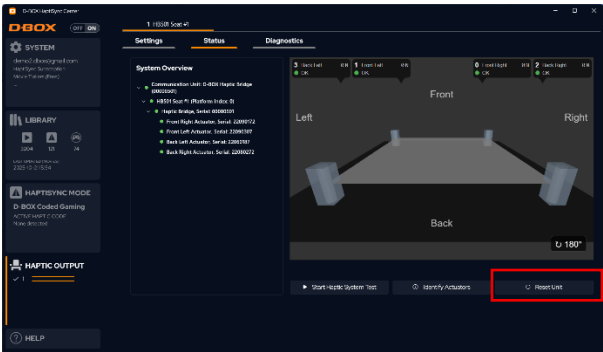

STEP 2: Under the Diagnostics tab, check the real-time condition of the haptic system. When a component fails, related information appears in red.

Fault

1 HB501 Seat #1						
Settings	Status	Diagnostics				
	Comm Unit	ACMO	Actuator Front Right	Actuator Front Left	Actuator Back Left	Actuator Back Right
Overall State	OK	OK	OK	OK	OK	Fault
Fault (s)						Connection Port
Interface Index		0	1	2	3	4
Type	Haptic Bridge	Haptic Bridge	Haptic Actuator	Haptic Actuator	Haptic Actuator	Haptic Actuator
Configured Model Name			AC218 SM0602	AC218 SM0602	AC218 SM0602	AC218 SM0602
Orientation			Vertical	Vertical	Vertical	Vertical
Configuration Code		10774	10774	10774	10774	10774
Serial (Interface)	00000501	00000501	00001873	00001764	00001988	00001411

STEP 3: See [Faults and Corrective Actions](#) for possible causes and corrective actions.

12.6 Faults and Corrective Actions

This is a list of faults you can find under the Diagnostics tab of the Haptic Output tab, including causes and corrective actions.

FAULTS	CAUSES	CORRECTIVE ACTIONS
<p>ACM Communication Lost Fault</p>	<p>Power and/or network cable disconnected.</p>	<p>Make sure the power, USB, and network cables (if applicable) are securely plugged in.</p> <p>Inspect the entire length of the network cable for obvious signs of damage.</p> <p>Make sure your Haptic Actuator is connected to a grounded electrical outlet.</p> <p>NOTE: Do not use adapter plugs or remove the grounding prong from cables. If you must use an extension cable, use a 3-wire cable with properly grounded plugs.</p>
<p>Actuator Hard Fault</p>	<p>Something may be blocking the Haptic Actuator. This is a Hard fault.</p> <p><i>The faulty Haptic Actuator is immediately deactivated, and all other Haptic Actuators go to their lowest position.</i></p>	<p>Check if there is anything blocking the travel of the Haptic Actuator.</p> <p>Power off the haptic system, support your platform to gain access to the Haptic Actuator piston and slowly pull it out of its body until the entire piston is out, and then slowly push it back in.</p> <p>If the error persists, replace/arrange to repair the faulty Haptic Actuator.</p>
<p>Bridge Temperature Sensor Fault</p>	<p>This error can be triggered by starting the haptic system when the temperature is too low.</p> <p>The internal power bridge sensor is defective.</p>	<p>Make sure your haptic system is running in a temperature range between 0 to 40°C.</p> <p>Make sure there is sufficient airflow around the Haptic Actuator.</p> <p>If the problem persists, replace/arrange to repair the faulty Haptic Actuator.</p>
<p>Command Overrun Fault</p>	<p>A new command was received by the Haptic Actuator while the previous command had not completed.</p> <p><i>This should not be a permanent fault and should clear after a while.</i></p>	<p>Reset your haptic system in the Haptic Output tab of D-BOX HaptiSync Center, under either the Settings or Status tab by clicking the Reset Unit button.</p> <p>Power off the haptic system, wait for a minute, then try again.</p> <p>In HaptiSync Center, check if there are any other faults and follow the recommended solution.</p>

FAULTS	CAUSES	CORRECTIVE ACTIONS
		<p>If the error persists, contact your reseller support team or D-BOX Technical Support if your system was purchased directly from D-BOX.</p>
<p>Critical Actuator Fault</p>	<p>Something may be blocking the actuator. This is a Hard fault.</p> <p><i>The faulty Haptic Actuator is immediately deactivated to prevent damage, and all other actuators go to the lowest position.</i></p>	<p>Check if there is anything blocking the travel of the Haptic Actuator.</p> <p>Power off the haptic system, support your platform to gain access to the Haptic Actuator piston and slowly pull it out of its body until the entire piston is out, and then slowly push it back in .</p> <p>If the error persists, replace/arrange to repair the faulty Haptic Actuator.</p> <p>If the error persists, replace the Haptic Bridge.</p>
<p>Encoder Fault</p>	<p>There is a problem associated with the motor encoder.</p>	<p>Power off the haptic system, wait for a minute, then try again.</p> <p>If the error persists, replace/arrange to repair the faulty Haptic Actuator.</p>
<p>High Voltage Rail Overvoltage Fault</p>	<p>Too high a voltage detected.</p> <p>Voltage from the wall outlet is too high for the haptic system.</p>	<p>Verify that all Haptic Actuators are set to your region's power voltage.</p> <p>Make sure you are not connected to a GFI breaker.</p> <p>Check the power coming out of the outlet and make sure it respects the specified operating conditions. When in doubt, connect the haptic system to another circuit.</p>
<p>High Voltage Rail Undervoltage Fault</p>	<p>Too low a voltage detected.</p> <p>Voltage from the wall outlet is too low for the haptic system.</p>	<p>Visually inspect the entire length of the power cable for obvious signs of damage.</p> <p>Make sure you are connected to a grounded electrical outlet.</p>
<p>Logic Voltage Undervoltage Fault</p>	<p>Too low a voltage detected.</p> <p>Defective or disconnected power cable.</p> <p>Low-voltage rail is too low.</p>	<p>NOTE: Do not use adapter plugs or remove the grounding prong from cables. If you must use an extension cable, use a 3-wire cable with properly grounded plugs.</p> <p>If you are using an extension cable, try again without it.</p> <p>If the error persists, replace/arrange to repair the faulty Haptic Actuator.</p>

FAULTS	CAUSES	CORRECTIVE ACTIONS
<p>Motor Temperature High Fault</p>	<p>The motor temperature detector has failed or disconnected.</p>	<p>Make sure that the maximum supported weight for the platform has not been exceeded.</p> <p>Make sure that the weight is evenly distributed among the Haptic Actuators of the platform (as centered as possible).</p>
<p>Motor Temperature Sensor Fault</p>	<p>The temperature is too low.</p> <p>If the temperature shown is around 561°F, it may be a defective motor cable or temperature sensor.</p>	<p>The weight limit (in "D-BOX Newtons") is lower than 1900 N. Confirm this in the Haptic Output tab of D-BOX HaptiSync Center, under Diagnostics.</p> <p>Make sure the haptic system is operating in normal operating conditions (room temperature).</p> <p>If the error persists, replace/arrange to repair the faulty Haptic Actuator.</p>
<p>Out of bounds Fault</p>	<p>The position of the Haptic Actuator is over its limits. (Should never occur in normal conditions).</p> <p>The haptic code may have sent the Haptic Actuator out of bounds.</p>	<p>Verify that you are running a D-BOX-certified haptic code. Call D-BOX Technical Support for validation if necessary.</p> <p>Perform a test by clicking Start Haptic System Test on the Haptic Output tab of D-BOX HaptiSync Center.</p>
<p>Overcurrent Fault</p>	<p>A Haptic Actuator might have the wrong configuration (e.g. for a 250-lb motor instead of a 400-lb).</p>	<p>Make sure you have the right configuration using D-BOX System Configurator.</p> <p>If the error persists, contact your reseller support team or D-BOX Technical Support if your system was purchased directly from D-BOX.</p>
<p>Overweight Fault</p>	<p>There is too much weight on the platform.</p> <p>The weight on the platform is unbalanced.</p>	<p>Make sure that the maximum supported weight for the platform has not been exceeded.</p> <p>Make sure that the weight is evenly distributed among the Haptic Actuators of the platform (as centered as possible).</p> <p>The weight limit (in "D-BOX Newtons") is lower than 1900 N. Confirm this in the Haptic Output tab of D-BOX HaptiSync Center, under Diagnostics.</p> <p>If the error persists, contact your reseller support team or D-BOX Technical Support if your system was purchased directly from D-BOX.</p>
<p>Power Bridge Temperature High</p>	<p>The Haptic Actuator power bridge has</p>	<p>Power off the haptic system, wait for a minute then try again.</p>

FAULTS	CAUSES	CORRECTIVE ACTIONS
	overheated, or the sensor is defective.	<p>Let the system cool down for a while and see if the temperature cools within normal limits.</p> <p>If the error persists, contact your reseller support team or D-BOX Technical Support if your system was purchased directly from D-BOX.</p>
Soft Actuator Fault	This fault is always accompanied by another fault, which is the primary reason (fault).	Consult the solution for the primary fault causing the Soft Actuator fault.
Temporary Actuator Fault	This fault is always accompanied by another fault, which is the primary reason (fault).	Consult the solution for the primary fault causing the Temporary Actuator Fault.
Travel Fault	<p>The travel distance during the search-stop procedure is too large or too small.</p> <p>An external factor is preventing the Haptic Actuator from moving.</p> <p>A defective Haptic Actuator.</p> <p>A communication issue with the encoder.</p>	<p>Check if there is anything blocking the travel of the Haptic Actuator.</p> <p>Power off the haptic system, support the platform to gain access to the Haptic Actuator piston and slowly pull it out of its body until the entire piston is out, and then slowly push it back in.</p> <p>If error persists, replace/arrange to repair the faulty Haptic Actuator.</p>

12.7 Troubleshooting Software Issues (D-BOX HaptiSync Center)

This section covers the procedure for fixing issues related to the host software (game) or haptic code.

STEP 1: Open D-BOX HaptiSync Center and make sure the game is installed properly.

STEP 2: Make sure you are using the latest version of [HaptiSync Center](#).

STEP 3: Make sure that your HaptiSync Mode is set to **D-BOX Coded Gaming**.

STEP 4: In the Haptic Output tab, start a motion and communication test by clicking **Start Haptic System Test**.

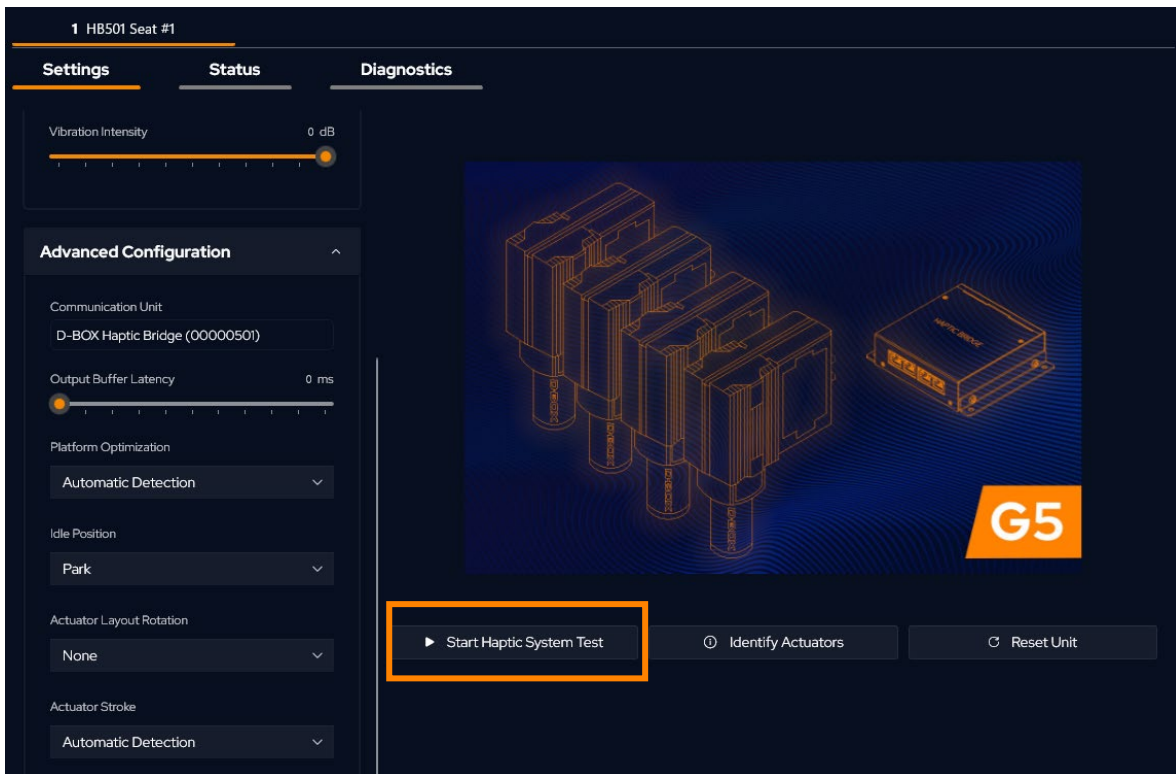

STEP 5: Make sure you have the latest version of the haptic code installed. If there is a newer version available, click **Update Haptic Code**.

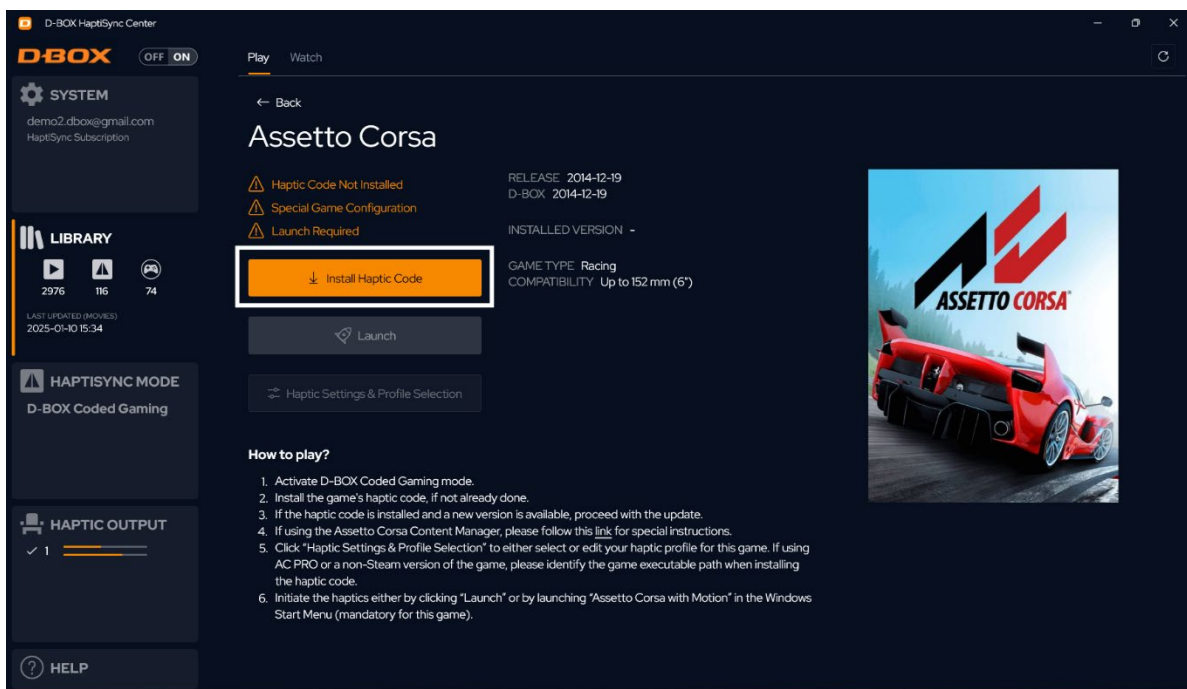

STEP 6: Make sure to launch the game from HaptiSync Center. Select the game then click the **Launch** button at the bottom.

NOTE: Some games may need to be launched in a specific way. Follow the instructions.

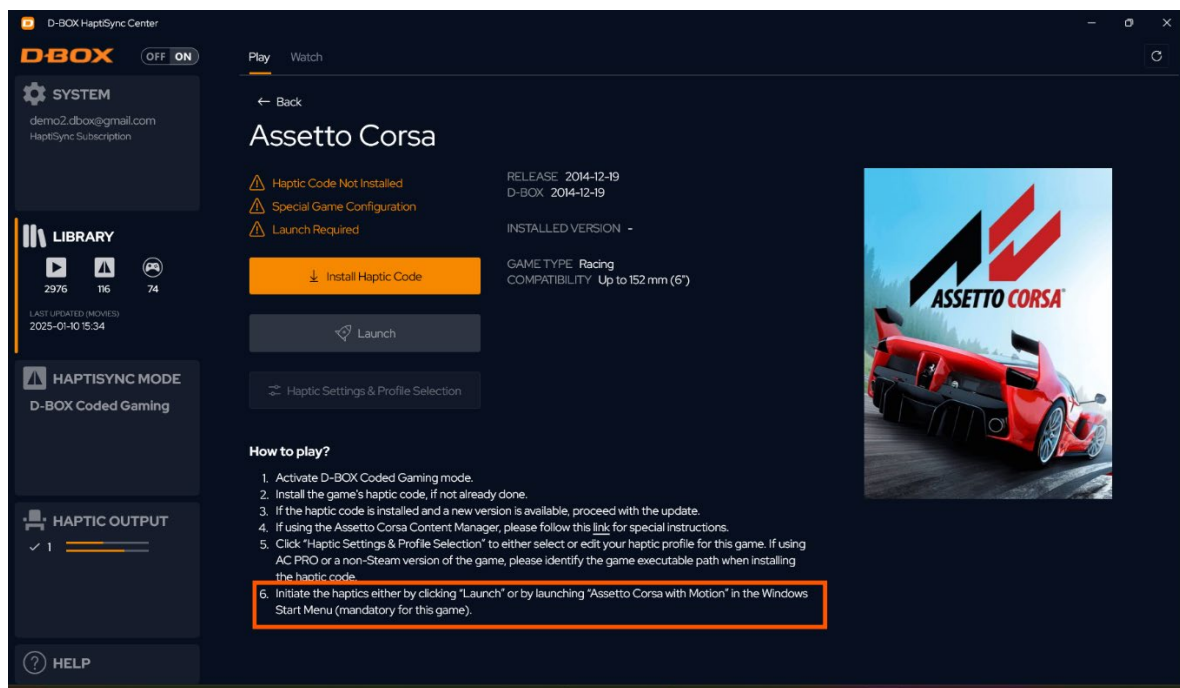

WWW.SIMULTIMATE.EU

APPENDIX A - MIXING G5 AND G3 HAPTIC SYSTEMS (ACM G3 FLEX ONLY)

These configurations require connecting your PC to a KCU-1P—the KCU-1P to the main ACM G3 FLEX—the main ACM G3 FLEX to a Haptic Expander— Haptic Expander to the G5 actuators.

NOTE:

- Remember to update your firmware whenever making a change to your setup/configuration.
- A Haptic Expander (HX4) is required when mixing a G3 haptic system (ACM G3 FLEX only) using one or more actuators (maximum of four) and a G5 haptic system using two or more actuators (connected to the REMOTE port of the Main ACM).

Option 1 (4 G5s Roll-Pitch-Heave/1 or 2 G3s Yaw, Sway, Surge, Yaw-Sway, Yaw-Surge, or Sway-Surge)

Configuration # 1095, 1096, 1097, 1098, 1099, or 1100

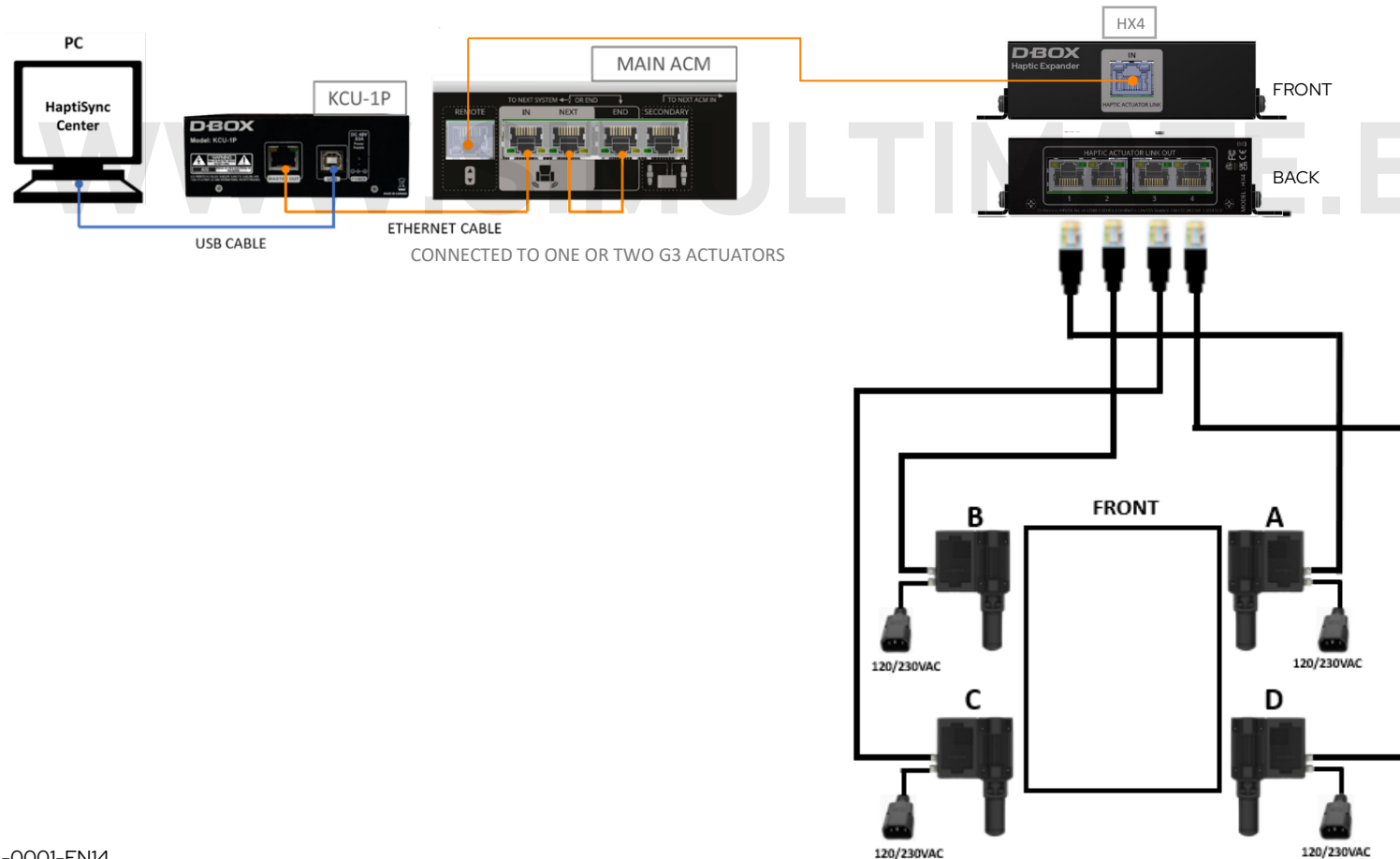

Option 2 (4 G5s Roll-Pitch-Heave / 3 G3s Yaw-Sway-Surge)

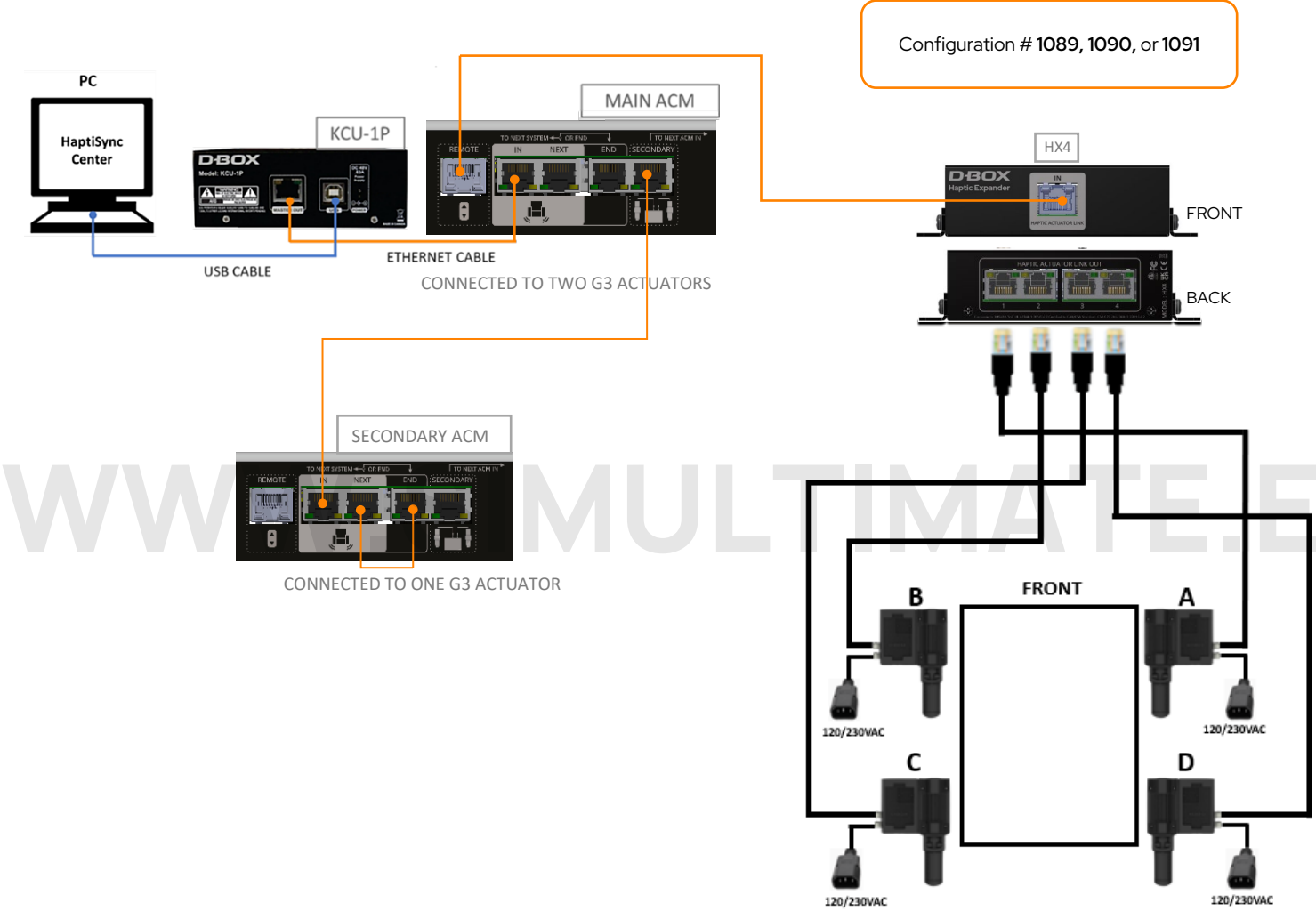

WWW.MULTIMATE.EU

Option 3 (4 G3s Roll-Pitch-Heave/2 G5s Yaw-Sway, Yaw-Surge, or Sway-Surge)

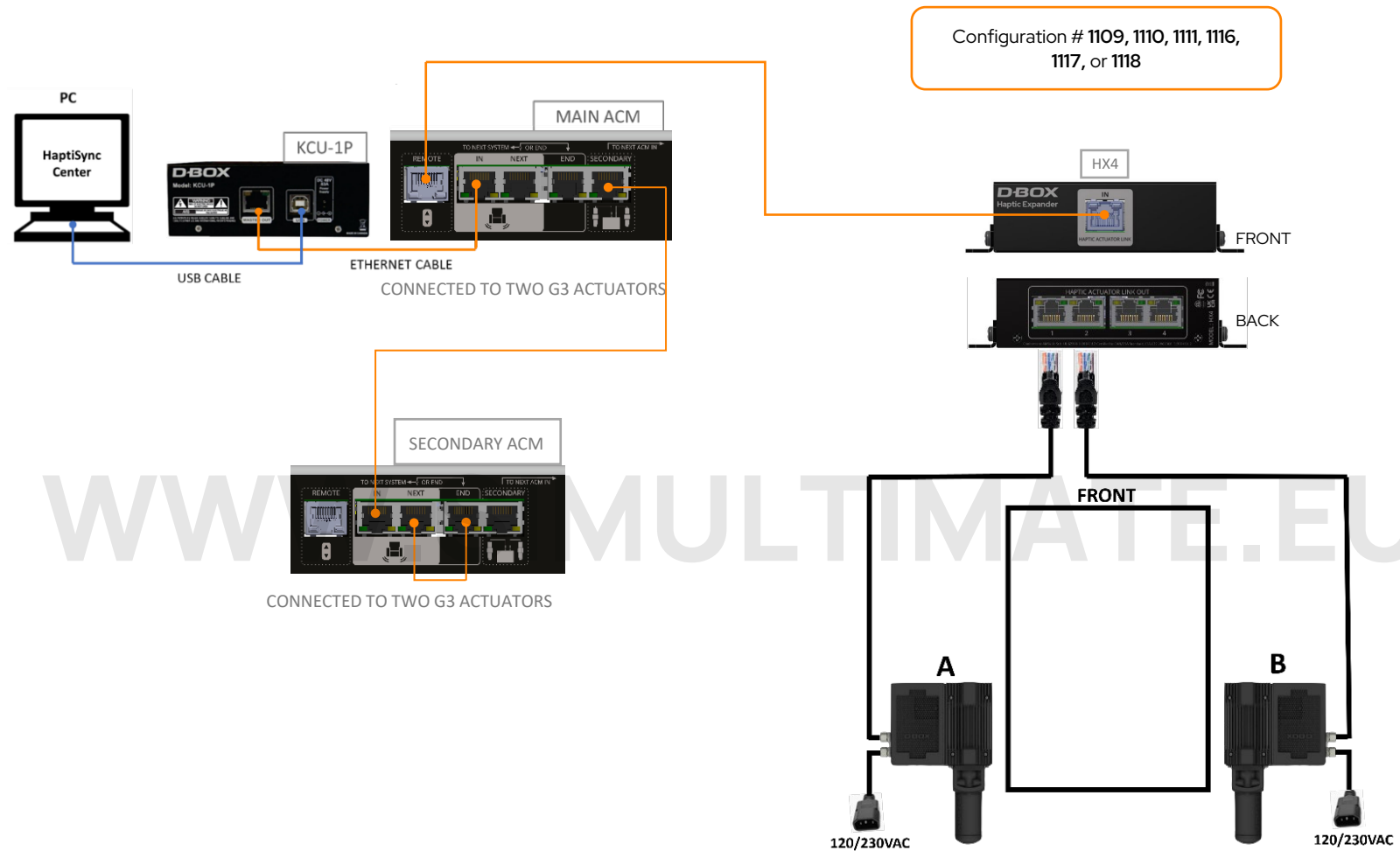

Common Configurations

NOTE: The following list does not represent every possible mixed configuration. See the System Configurator for more information.

Actuators	Number of ACM G3 FLEX	Configuration #	Description
4-G5, 1-G3	1	1098	G5 Roll-Pitch-Heave / G3 Yaw (M-Y1, S-FR0, S-FLO, S-BLO, S-BR0)
4-G5, 1-G3	1	1099	G5 Roll-Pitch-Heave / G3 Sway (M-Sw1, S-FR0, S-FLO, S-BLO, S-BR0)
4-G5, 1-G3	1	1100	G5 Roll-Pitch-Heave / G3 Surge (M-Su1, S-FR0, S-FLO, S-BLO, S-BR0)
4-G5, 2-G3	1	1095	G5 Roll-Pitch-Heave / G3 Yaw-Sway (M-Y0-Sw1, S-FR0, S-FLO, S-BLO, S-BR0)
4-G5, 2-G3	1	1096	G5 Roll-Pitch-Heave / G3 Yaw-Surge (M-Y0-Su1, S-FR0, S-FLO, S-BLO, S-BR0)
4-G5, 2-G3	1	1097	G5 Roll-Pitch-Heave / G3 Sway-Surge (M-Sw0-Su1, S-FR0, S-FLO, S-BLO, S-BR0)
4-G5, 3-G3	2	1089, 1090 or 1091	G5 Roll-Pitch-Heave / G3 Yaw-Sway-Surge 1089 (M-Y0-Sw1, S-Su1, S-FR0, S-FLO, S-BLO, S-BR0) 1090 (M-Y0-Su1, S-Sw1, S-FR0, S-FLO, S-BLO, S-BR0) 1091 (M-Y1, S-Sw0-Su1, S-FR0, S-FLO, S-BLO, S-BR0)
3-G5, 4-G3	2	1108	G3 Roll-Pitch-Heave / G5 Yaw-Sway-Surge (M-FR0-FL1, S-BLO-BR1, S-Y0, S-Sw0, S-Su0)
3-G5, 4-G3	2	1115	G3 Roll-Pitch-Heave / G5 Yaw-Sway-Surge (M-FLO-BL1, S-BR0-FR1, S-Y0, S-Sw0, S-Su0)

Actuators	Number of ACM G3 FLEX	Configuration #	Description
2-G5, 4-G3	2	1109	G3 Roll-Pitch-Heave / G5 Yaw-Sway (M-FRO-FL1, S-BLO-BR1, S-Y0, S-Sw0)
2-G5, 4-G3	2	1116	G3 Roll-Pitch-Heave / G5 Yaw-Sway (M-FLO-BL1, S-BRO-FR1, S-Y0, S-Sw0)
2-G5, 4-G3	2	1110	G3 Roll-Pitch-Heave / G5 Yaw-Surge (M-FRO-FL1, S-BLO-BR1, S-Y0, S-Su0)
2-G5, 4-G3	2	1117	G3 Roll-Pitch-Heave / G5 Yaw-Surge (M-FLO-BL1, S-BRO-FR1, S-Y0, S-Su0)
2-G5, 4-G3	2	1111	G3 Roll-Pitch-Heave / G5 Sway-Surge (M-FRO-FL1, S-BLO-BR1, S-Sw0, S-Su0)
2-G5, 4-G3	2	1118	G3 Roll-Pitch-Heave / G5 Sway-Surge (M-FLO-BL1, S-BRO-FR1, S-Sw0, S-Su0)
1-G5, 4-G3	2	1112	G3 Roll-Pitch-Heave / G5 Yaw (M-FRO-FL1, S-BLO-BR1, S-Y0)
1-G5, 4-G3	2	1119	G3 Roll-Pitch-Heave / G5 Yaw (M-FLO-BL1, S-BRO-FR1, S-Y0)
1-G5, 4-G3	2	1113	G3 Roll-Pitch-Heave / G5 Sway (M-FRO-FL1, S-BLO-BR1, S-Sw0)
1-G5, 4-G3	2	1120	G3 Roll-Pitch-Heave / G5 Sway (M-FLO-BL1, S-BRO-FR1, S-Sw0)
1-G5, 4-G3	2	1114	G3 Roll-Pitch-Heave / G5 Surge (M-FRO-FL1, S-BLO-BR1, S-Su0)

Actuators	Number of ACM G3 FLEX	Configuration #	Description
1-G5, 4-G3	2	1121	G3 Roll-Pitch-Heave / G5 Surge (M-FLO-BL1, S-BR0-FR1, S-Su0)
4-G5, 2-G3	2	1092	G5 Roll-Pitch-Heave / G3 Yaw-Sway (M-Y1, S-Sw1, S-FR0, S-FLO, S-BLO, S-BR0)
4-G5, 2-G3	2	1093	G5 Roll-Pitch-Heave / G3 Yaw-Surge (M-Y1, S-Su1, S-FR0, S-FLO, S-BLO, S-BR0)
4-G5, 2-G3	2	1094	G5 Roll-Pitch-Heave / G3 Sway-Surge (M-Sw1, S-Su1, S-FR0, S-FLO, S-BLO, S-BR0)
4-G5, 3-G3	3	1088	G5 Roll-Pitch-Heave / G3 Yaw-Sway-Surge (M-Y1, S-Sw1, S-Su1, S-FR0, S-FLO, S-BLO, S-BR0)
3-G5, 4-G3	4	1101	G3 Roll-Pitch-Heave / G5 Yaw-Sway-Surge (M-FR1, S-FL1, S-BL1, S-BR1, S-Y0, S-Sw0, S-Su0)
2-G5, 4-G3	4	1102	G3 Roll-Pitch-Heave / G5 Yaw-Sway (M-FR1, S-FL1, S-BL1, S-BR1, S-Y0, S-Sw0)
2-G5, 4-G3	4	1103	G3 Roll-Pitch-Heave / G5 Yaw-Surge (M-FR1, S-FL1, S-BL1, S-BR1, S-Y0, S-Su0)
2-G5, 4-G3	4	1104	G3 Roll-Pitch-Heave / G5 Sway-Surge (M-FR1, S-FL1, S-BL1, S-BR1, S-Sw0, S-Su0)
1-G5, 4-G3	4	1105	G3 Roll-Pitch-Heave / G5 Yaw (M-FR1, S-FL1, S-BL1, S-BR1, S-Y0)
1-G5, 4-G3	4	1106	G3 Roll-Pitch-Heave / G5 Sway (M-FR1, S-FL1, S-BL1, S-BR1, S-Sw0)

Actuators	Number of ACM G3 FLEX	Configuration #	Description
1-G5, 4-G3	4	1107	G3 Roll-Pitch-Heave / G5 Surge (M-FR1, S-FL1, S-BL1, S-BR1, S-Su0)

WWW.SIMULTIMATE.EU